

AGIL - MODULAR UPS

Including Smart ByPass (SBP)

User Manual V7.6

RE-INVENTING THE MODULAR UPS

THE NEW GENERATION OF POWER CONVERTERS

- » **SELECTIVITY**
Adapted response to short circuit and overload
- » **VERSATILE CHARGING**
Short or long backup recovery time at no extra cost
- » **BATTERY SUSTAINABILITY**
Qualitative charging for longer battery life expectancy
- » **HARSHEST AC INPUT CONDITIONS**
Without compromising the quality of the AC output



Table of Contents

1. CE+T Power at a glance.....	5
2. Abbreviations.....	6
3. Introduction	7
3.1 Scope of the manual	7
3.2 User Interface presentation.....	7
3.2.1 AGIL UPS module User Interface	7
3.2.2 T4S supervisor	11
3.2.3 CATENA GUI Interface	12
4. Installation	14
4.1 Schematic Diagram - Common Input Source for AGIL with SBP + MBP	15
4.2 Schematic Diagram - Dual Input Source for AGIL with SBP + MBP	16
5. T4S/CATENA start-up	18
5.1 Applying start-up power	18
6. Standard Features.....	19
6.1 AC Input Sub-menu	20
6.2 DC Battery Sub-menu	20
6.3 AGIL Modules Sub-menu	21
6.3.1 AGIL Modules Sub-menu.....	21
6.4 AC Output Load Sub-menu	23
6.5 SBP Modules Sub-menu.....	23
6.5.1 SBP Modules Sub-menu.....	24
7. Toolbar.....	25
7.1 Events and Log.....	25
7.2 Input, output mapping	26
7.3 Files	27
7.4 Parameters.....	28
7.4.1 Monitoring.....	28
7.4.2 Communication	30
7.4.3 Digital Input and output relay mapping	31
7.4.4 Power parameter setting	33
7.4.5 Battery 1 and Battery 2	37
7.4.6 Info	39
8. AGIL / SBP module and Fan replacement	40
8.1 AGIL / SBP module replacement	40
8.2 Fan Replacement	41
9. Factory Ranges and Defaults.....	42
9.1 Definition.....	43

10. SNMP V1 & SNMP V3 Configuration.....	44
10.1 SNMPv1 configuration.....	44
10.2 SNMPv1 MIB (RFC1628).....	44
10.3 SNMPv3 configuration.....	44
11. ModBus RTU.....	46
11.1 Physical Connection.....	46
11.2 Configuration.....	47
11.3 Tables.....	47
ANNEXE 1. Battery Management with AGIL Technology and T4S.....	48
1.1. Introduction.....	48
1.2. CE+T Battery charging and discharging MODE.....	48
ANNEXE 2. AGIL Manual Bypass (MBP).....	52
2.1. Introduction.....	52
2.2. Principle of operation.....	52
2.3. Presentation.....	53
2.4. MBP Wiring.....	54
ANNEXE 3. AGIL Smart By-Pass (SBP).....	55
3.1. Introduction.....	55
3.2. Principle of Operation.....	55
3.3. SBP LEDs Indication.....	56
3.4. SBP Breaker Selection.....	56
ANNEXE 4. T4S Alarms.....	57
4.1. Supervisor alarms: T4S.....	57
ANNEXE 5. FAQ.....	66

Release Note:

Version	Release date (DD/MM/YYYY)	Modified page number	Modifications
7.0	06/01/2014	-	First release of the Manual.
7.1	28/05/2014	7 and 9	Modified picture
		13	Added Note
		14	Password details updated
		27 to 30	Text updated
		34	Table updated
7.2	05/06/2015	-	SBP Information
7.3	23/12/2015	-	Amendment and correction.
7.4	05/01/2018	-	Updated the pictures and information
7.5	29/01/2018	36	Updated the values
7.6	18/02/2019	-	Boost function



Leading AC Backup Technology

CE+T Power at a glance

1. CE+T Power at a glance

CE+T Power designs, manufactures and markets a range of products for industrial operators with mission critical applications, who are not satisfied with existing AC backup systems performances, and related maintenance costs.

Our product is an innovative AC backup solution that unlike most used UPS's

- Maximizes the operator's applications uptime;
- Operates with lowest OPEX;
- Provides best protection to disturbances;
- Optimizes footprint.

Our systems are:

- Modular
- Truly redundant
- Highly efficient
- Maintenance free
- Battery friendly

CE+T power puts 60+ years expertise in power conversion together with worldwide presence to provide customized solutions and extended service 24/7 - 365.

2. Abbreviations

TSI	Twin Sine Innovation
EPC	Enhanced Power Conversion
REG	Regular
DSP	Digital Signal Processor
AC	Alternating current
DC	Direct current
ESD	Electro Static Discharge
MET	Main Earth Terminal
MBP	Manual By-pass
TCP/IP	Transmission Control Protocol/Internet Protocol
USB	Universal Serial Bus
PE	Protective Earth (also called Main Protective Conductor)
N	Neutral
PCB	Printed Circuit Board
TRS	True Redundant Structure
MCB	Miniature Circuit Breaker
MCCB	Molded Case Circuit Breaker
CB	Circuit Breaker

3. Introduction

3.1 Scope of the manual

This document describes the software features, on-site setup and operation of the AGIL Modular Power system. Please refer to AGIL Installation manual for hardware installation and wiring information.

3.2 User Interface presentation

3.2.1 AGIL UPS module User Interface

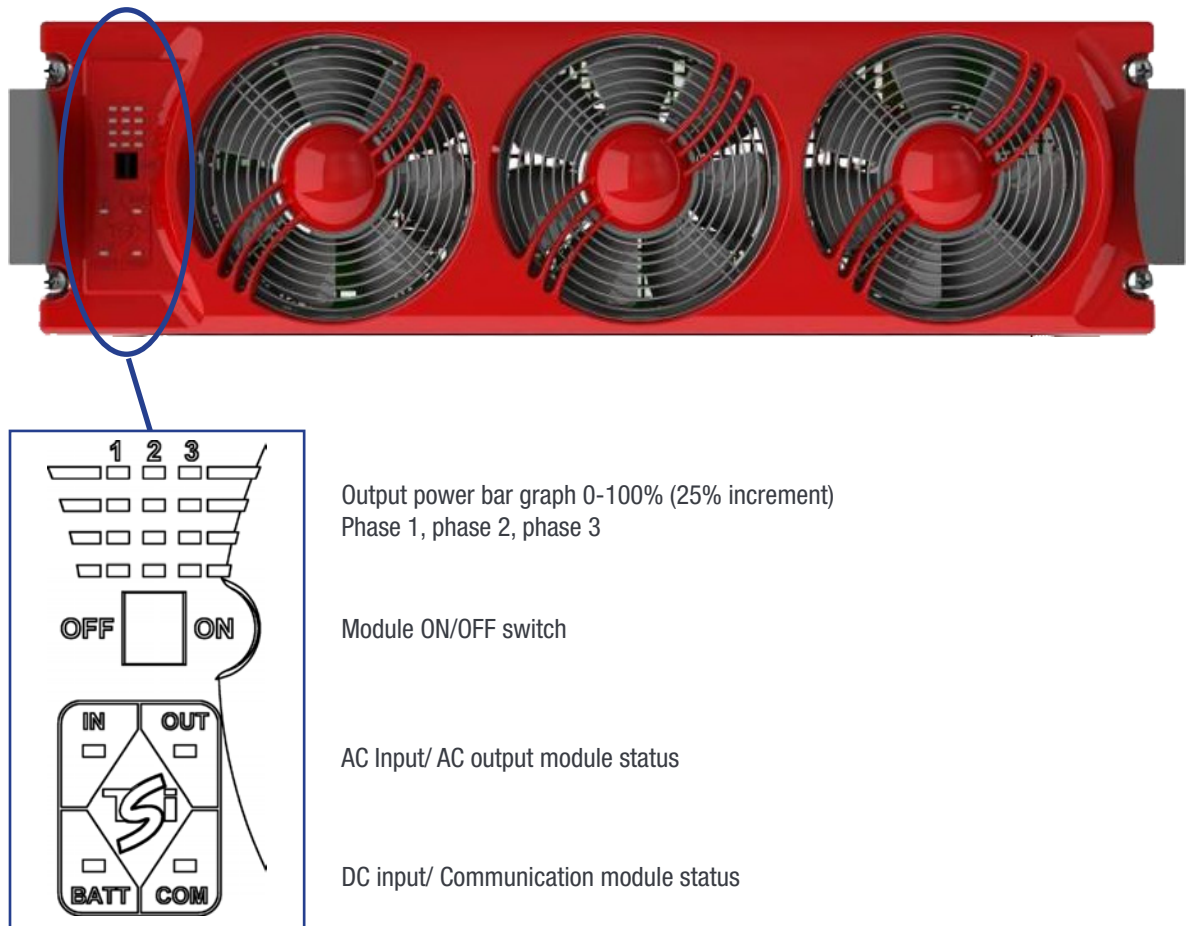

3.2.1.1 Output Power LED interface :

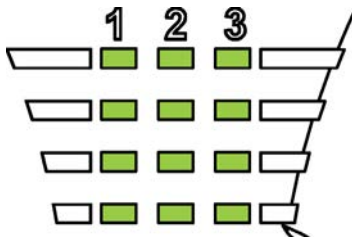

Each segment represent 25% load.
0-25 / 25,1-50 / 50,1-75 / 75,1-100

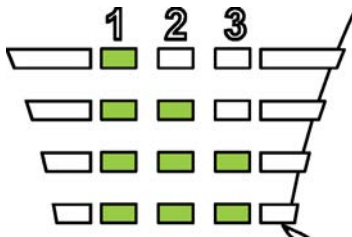

Load can differ between the 3 phases in one module
Load can differ in one phase in several modules

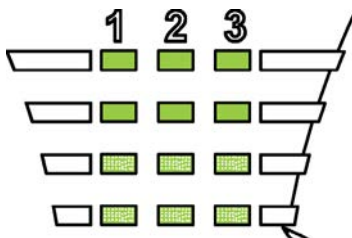

Overload (blinking)
100% - 110% segment 0-25 blinking
110,1% - 135% segment 0-50 blinking

3.2.1.2 Module status LEDs interface

AC input LEDs interface

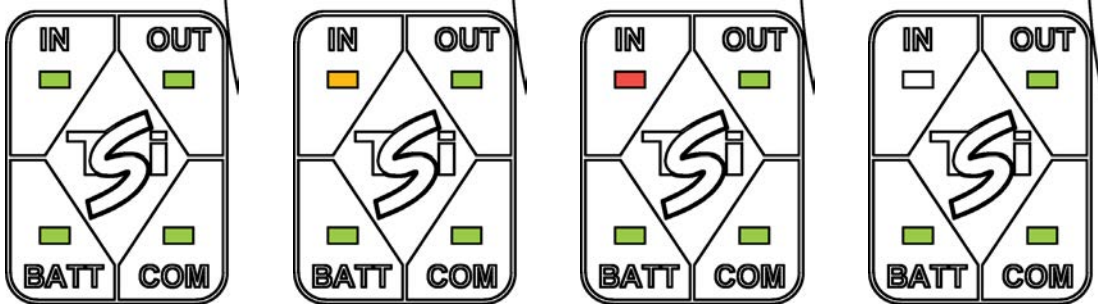

Starting up	(all LEDs)	OFF
AC Input OK	(within limits)	GREEN
AC Input not OK	(out of limits)	ORANGE
	(Auto restart)	Flash ORANGE
	(Manual restart)	Flash RED
	(Non recoverable)	RED
AC failure		OFF + external alarm

AC output LEDs interface

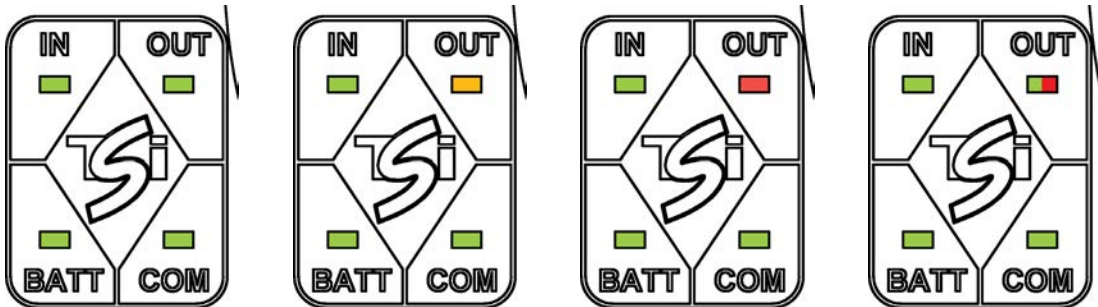

Starting up	()	GREEN Blink
AC Output OK	(within limits)	GREEN
AC Output not OK	(out of limits)	ORANGE
	(auto restart)	ORANGE Blink
	(manual restart)	RED Blink
	(non recover)	RED
Remote OFF	(man restart)	OR/GR/OR/GR
		sequence every x seconds

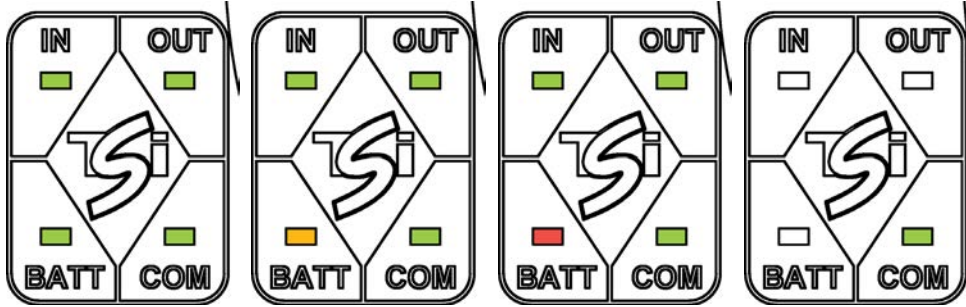

Starting up	()	OFF
DC OK	(within limits)	GREEN
DC not OK	(out of limits)	YELLOW
	(auto restart)	YELLOW Blink
	(man restart)	RED Blink
	(non recover)	RED
No battery		
connected	()	OFF

Communication LEDs interface

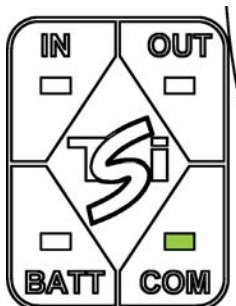

COM OK	()	GREEN
COM ERROR	(Bus A or B)	GREEN Blink still one bus present
COM ERROR	(Bus A & B)	RED Blink

Module and system will continue working with one BUS failing with two bus failing the module/system will isolate and shut down.

3.2.2 T4S supervisor

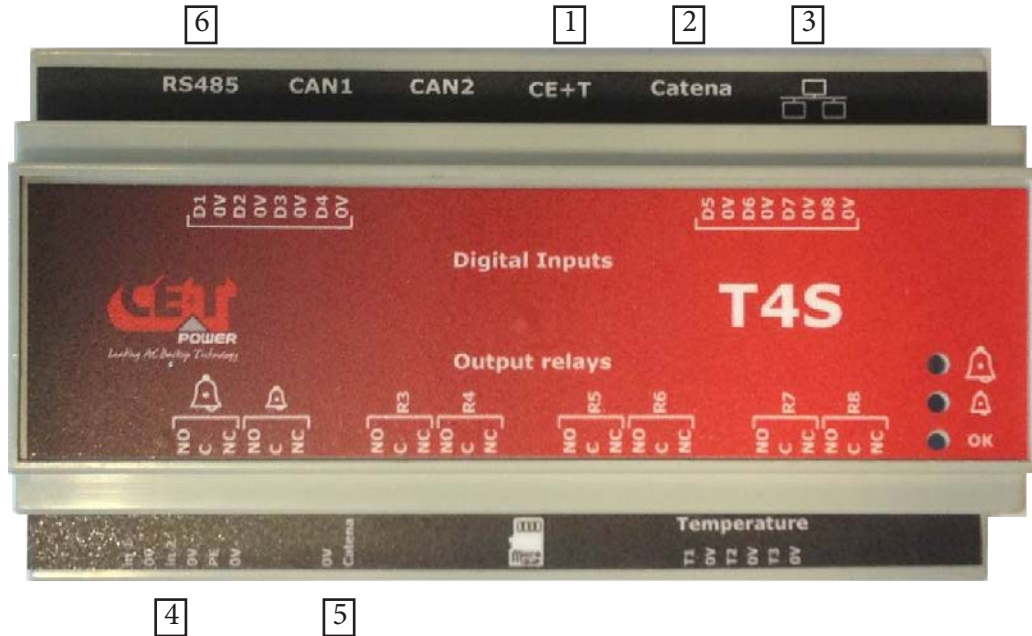

T4S supervisor monitors the AGIL module as well as system environment. It is connected to :

- The AGIL module through the CE+T bus [1].
- The Catena through the “Catena bus” [2].
- To Catena on left ETH port - see page 12 [3].

T4S has:

- 8 “digital input “ referred to has D1 to D8.
- 8 output relays Major Alarm, Minor Alarm, R3 to R8.
- 3 temperature probes T1 to T3. T1 should used for battery 1 and T2 for battery 2, T3 is not used for now.
- Dual DC input 12 V power supply (not included) [4].
- 12V output to be wired to Catena power supply” [5].
- Modbus is available on RS485 port [6]. See section page 46 for more information.

Please note the T4S and CATENA are not master and therefore can be removed during operation without affecting the operation of the UPS AC output.

3.2.3 CATENA GUI Interface

CATENA GUI interface allows the user to easily access the system monitoring via a powerful web based graphic display.

In addition to the touch-screen display the user can also access to the same GUI using an Ethernet port present on the T4S or CATENA.

3.2.3.1 Software Overview

The software embedded in T4S and CATENA allows complete system supervision through “touchscreen display” or via web browser, and provides functionalities such as:

- System setting and configuration (password protected).
- System status and information display.
- System alarms and events log file.
- System self-maintenance (battery test, battery boost charge, ...).

3.2.3.2 CATENA comes in two versions:

- Rack mounted where the unit takes 3U inside the cabinet flush mounted.
- Door or Panel mounted where the unit is fixed to the door or panel.

Catena - Rack Mounting Version



Remark: Reset will only reset the Catena, not the T4S and will have no effect on the system.

Power supply and connectivity are provided on the back of the unit:

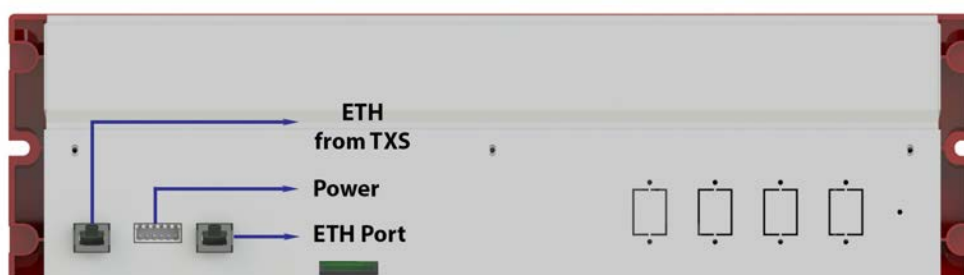

Catena - Door Mounting Version



To access the user interface, user has to connect through Ethernet port in Catena.

Installing the Door mount catena in the AGIL Cabinet door

Step 1. In the Cabinet Door, make 8 x M3 holes as per the catena support sheet dimensions.

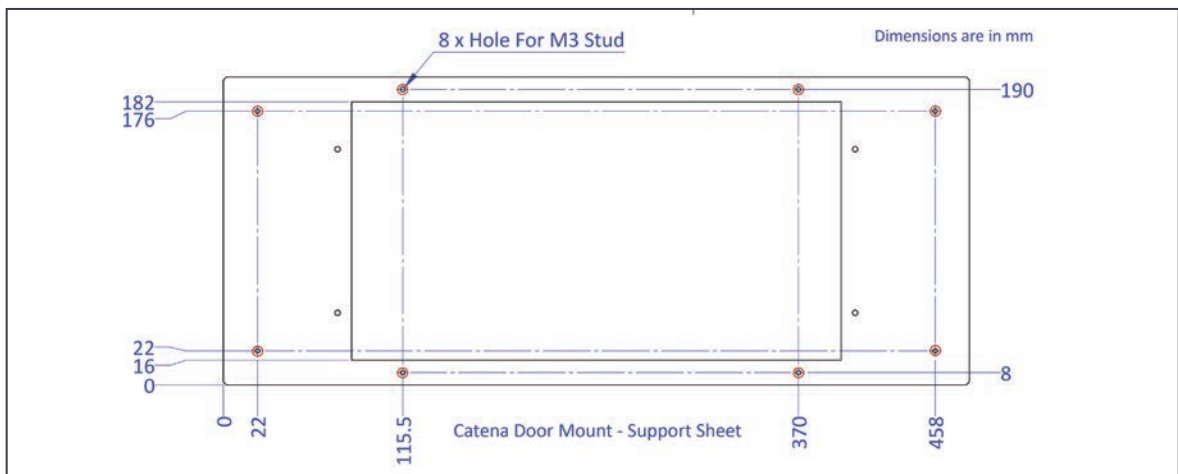

Step 2. Assemble the Door mount catena with the Catena support sheet using 4 x M3 Studs.

Step 3. Place the assembled catena into the cabinet door and fix it using 8 x M3 Studs.

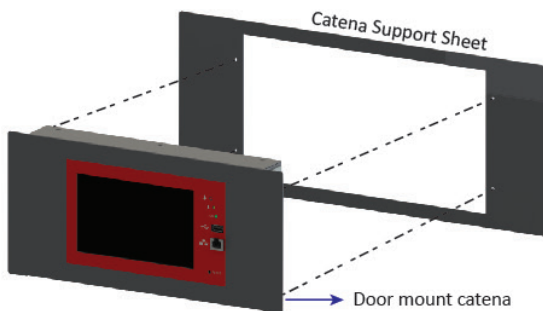

Assemble the Catena

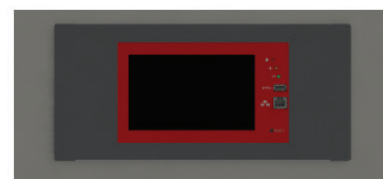

Fix Catena Assembly in the Cabinet door

4. Installation

T4S is a DIN rail mountable controller which is connected to the AGIL module / system as indicated in the schematic in next page

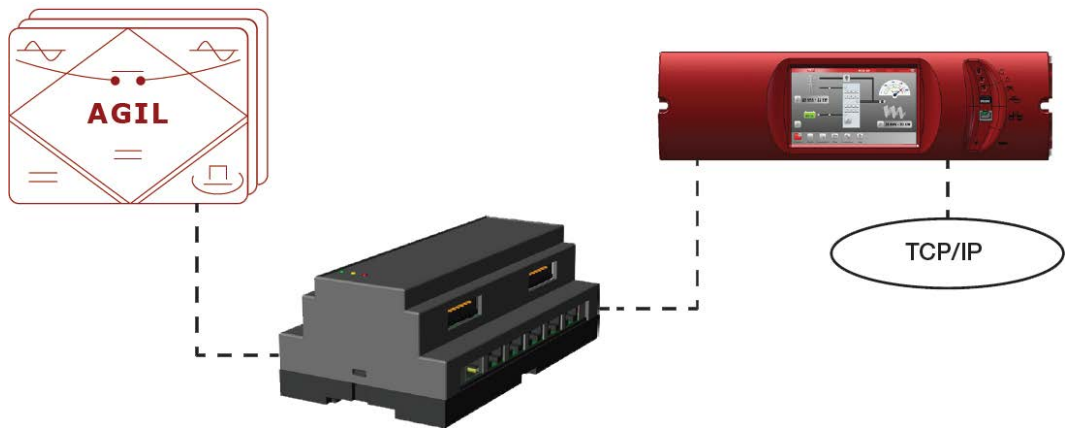

Remark: Catena acts as a switch on the network. Both T4S & Catena need IP address as they are both connected to the network.

See page 30 for tips on network configuration.

4.1 Schematic Diagram - Common Input Source for AGIL with SBP + MBP

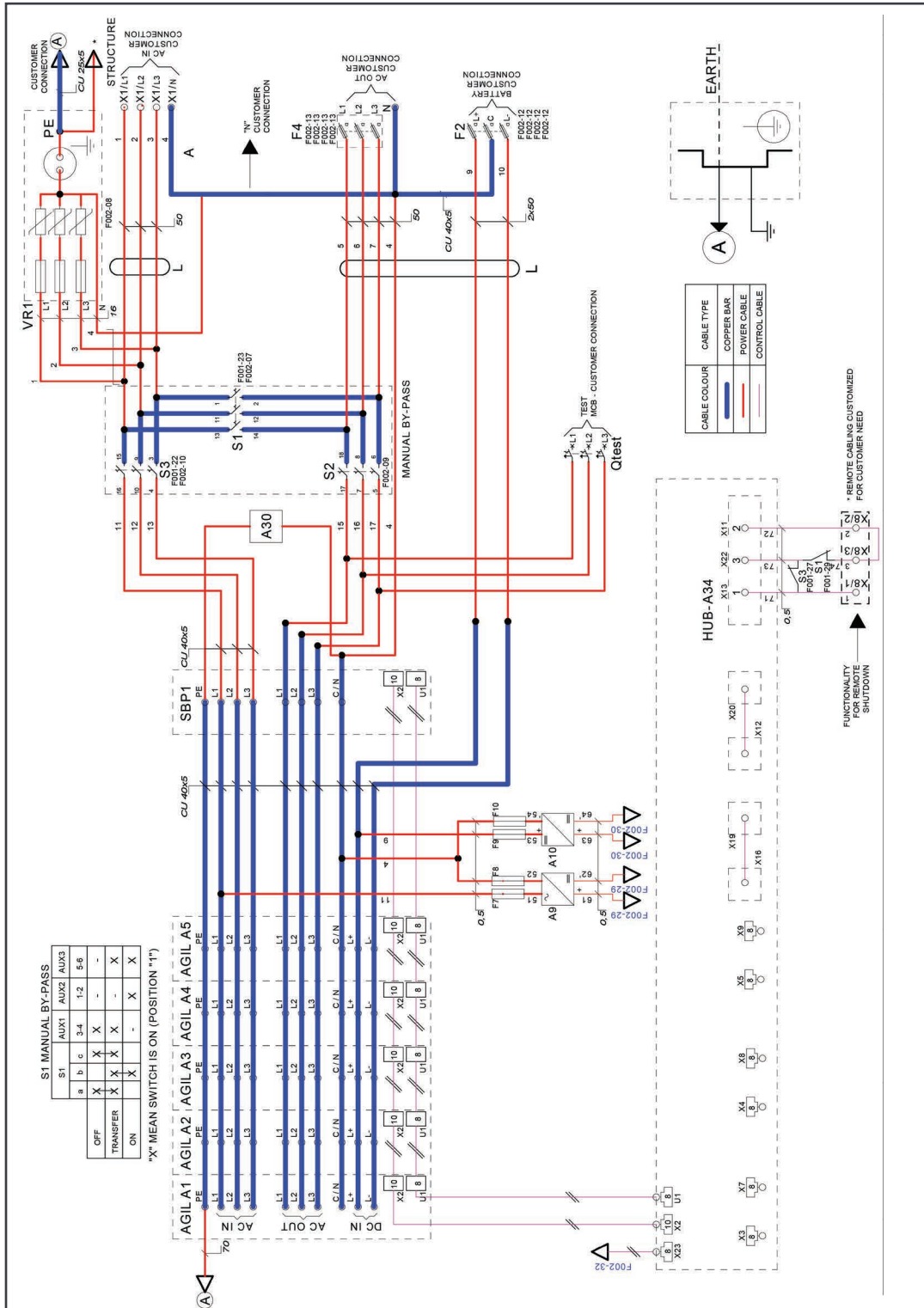

4.2 Schematic Diagram - Dual Input Source for AGIL with SBP + MBP

• Page 1

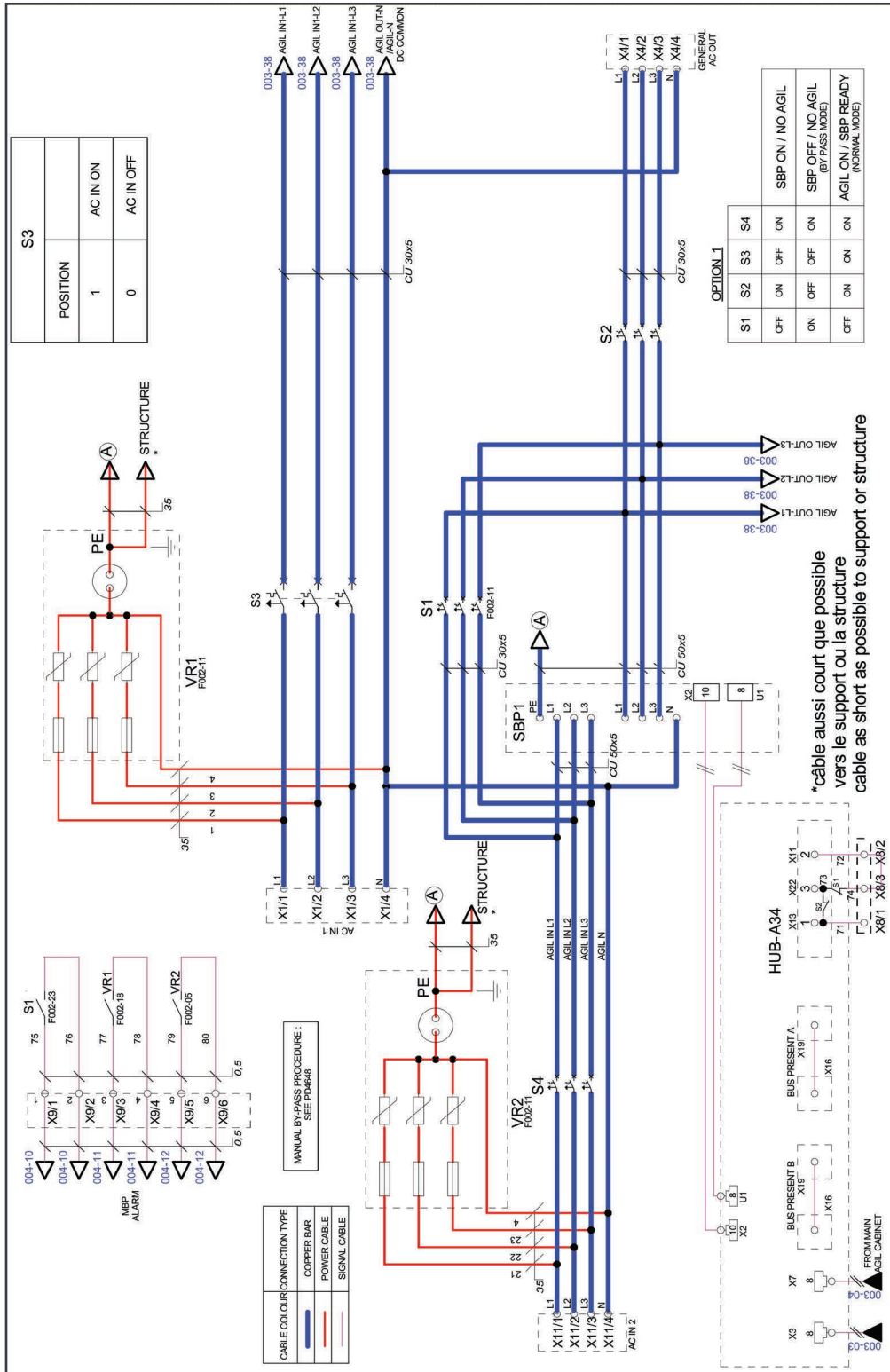

• Page 2

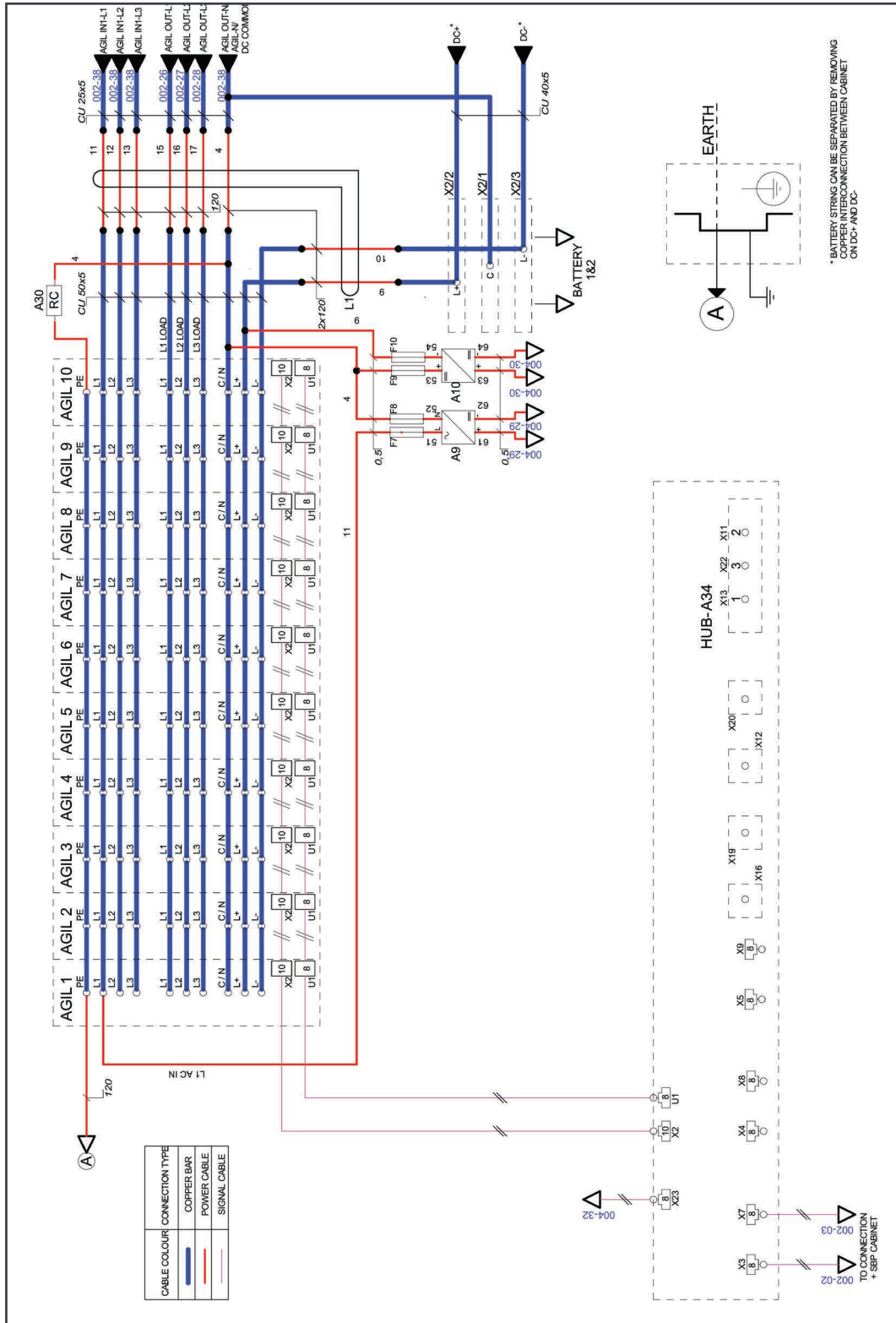

5. T4S/CATENA start-up

If you have installed the T4S and CATENA by yourself, make sure to respect the connections as indicated in the schematic.

If you have ordered the complete solution with cabinet and module from CE+T Power, both controllers are installed, wired, tested and preconfigured according to the system.

5.1 Applying start-up power

NOTE: The controller will perform a short self-test as it boots up. Alarm alerts are normal.

- Initiate the start-up routine by applying power to the T4S (close protection breaker powering the controller).
- Use the touchscreen or a laptop to connect to the system.

NB: if you are connecting with your laptop, default IP address of user interface is `http://192.168.0.2`

There are two access levels:

- Basic: after version 3.1, basic access does not require password. Before that, default password is *pass123*.
- Expert: default password is *pass456* but it's strongly advised to users to change that password.

In case of lost password, please refer to FAQ at page 66

- Check and adjust alarms and control levels in the controller sub-menus.
- Check and adjust battery settings in the battery sub-menus; e.g. float, equalize voltage, etc.
- If on touchscreen, check the communications settings for remote access as needed.

NOTE: System modification and setting may result in alarm event. Make sure you are applying modification carefully.

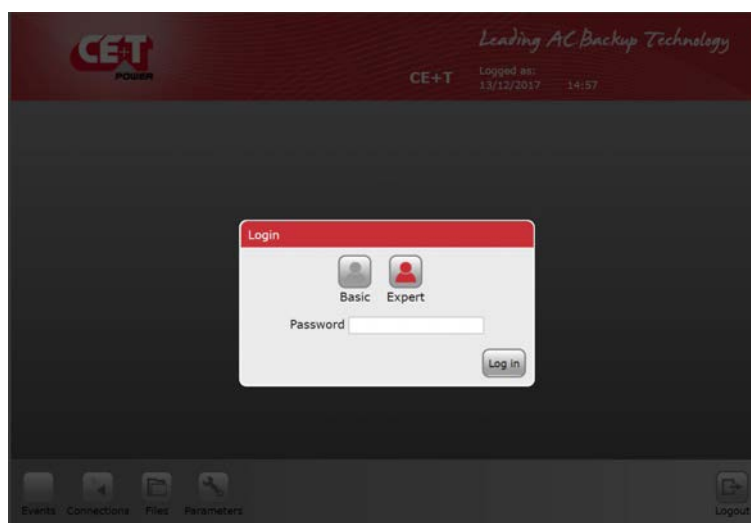

6. Standard Features

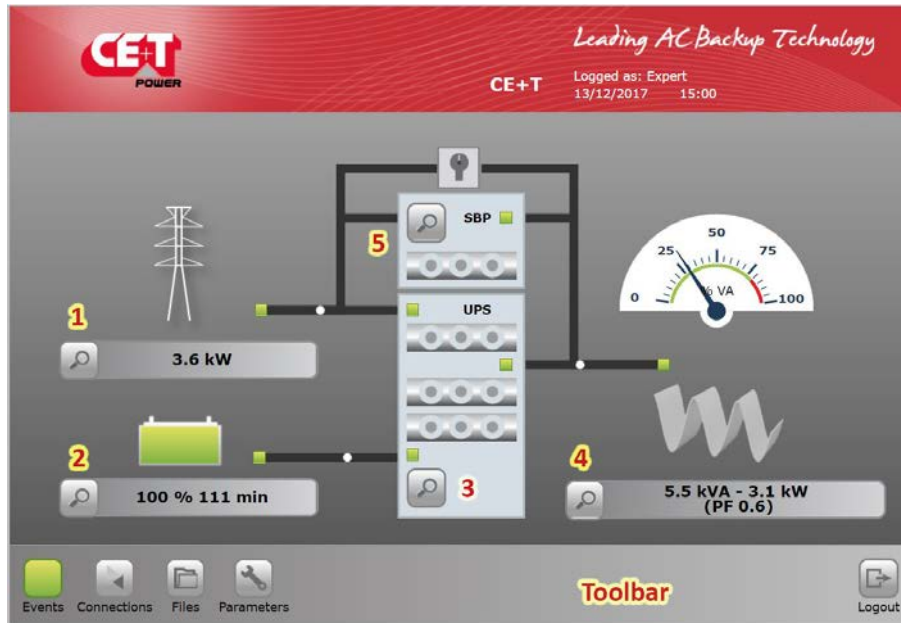

The main screen presents an overview of the system where any “click” on the magnifying glass icon will result to access the selected sub-menu:

- 1 → AC Input sub-menu.
- 2 → DC Battery sub-menu.
- 3 → AGIL Modules sub-menu.
- 4 → AC Output load sub-menu.
- 5 → SBP Modules sub-menu.

A click on an icon in the toolbar will give you, respectively, access to the event, communication, parameter, files sub-menu.

The main screen shows the status of each of your power system’s components.

- AC input: Green, Red.
- Battery: Green, Orange, Red.
- AGIL module(s): 3 LEDs (AC input , DC input, AC output).
- AC output / Load: Green, Red.

The energy flow direction is indicated by the “moving” white point on the power lines.

Standard Features

6.1 AC Input Sub-menu

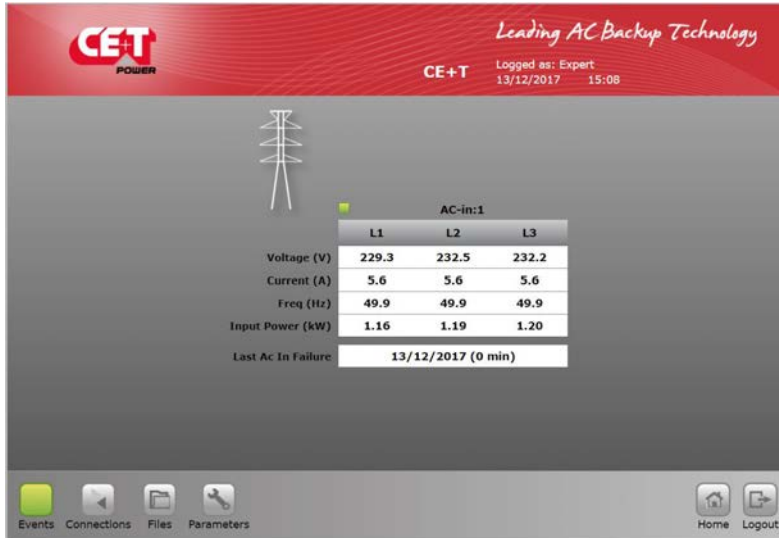

Provides AC input information (up to 3 phases).

- AC input voltage.
- AC input current.
- AC input Frequency.
- AC input Power (kW).

6.2 DC Battery Sub-menu

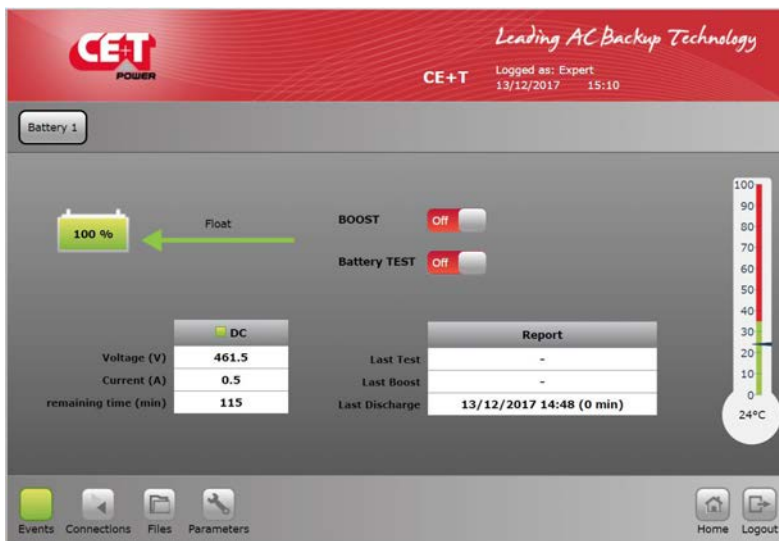

Battery x (x = 1 or 2) provide info on batteries status.

- BOOST ON or OFF
- Battery Test ON or OFF

Estimated autonomy and info on last test, boost charge, discharge

6.3 AGIL Modules Sub-menu

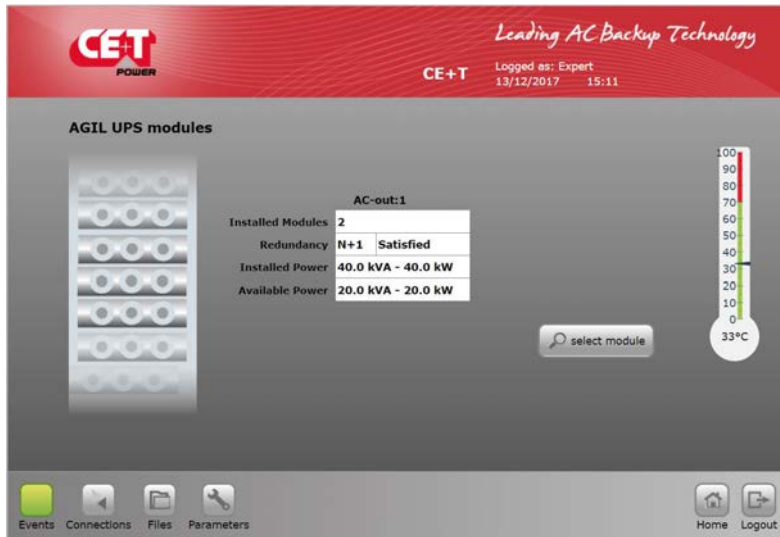

Provides AGIL module info

- Number of module installed
- Redundancy level
- Installed power.
- Available power.
- Temperature of the warmest module.

6.3.1 AGIL Modules Sub-menu.

Clicking on the “Select Module” icon will open a module selection table.

Each number represents the address of a module in the system.

- A green indicates an installed and running module.
- An orange indicates an installed but in recoverable error module.
- A red indicates an installed but in non-recoverable error module.
- A grey indicates a module manually turned OFF. Only available in “Expert” mode.
- A white indicates an empty slot.

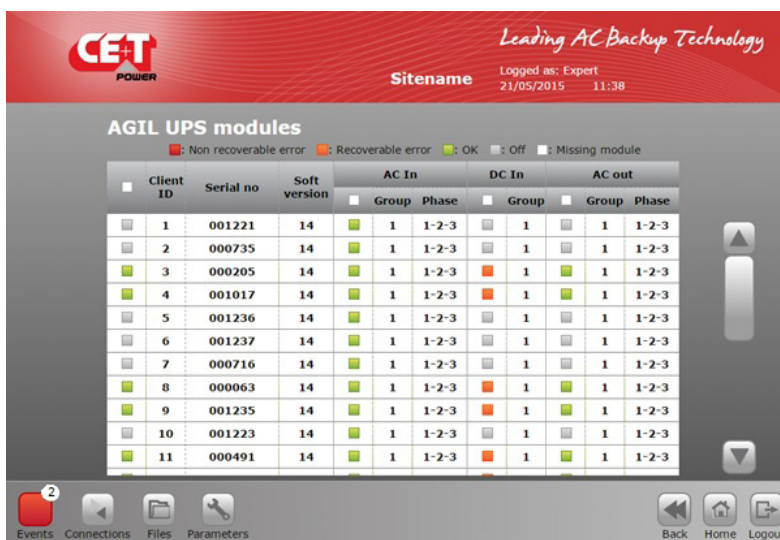
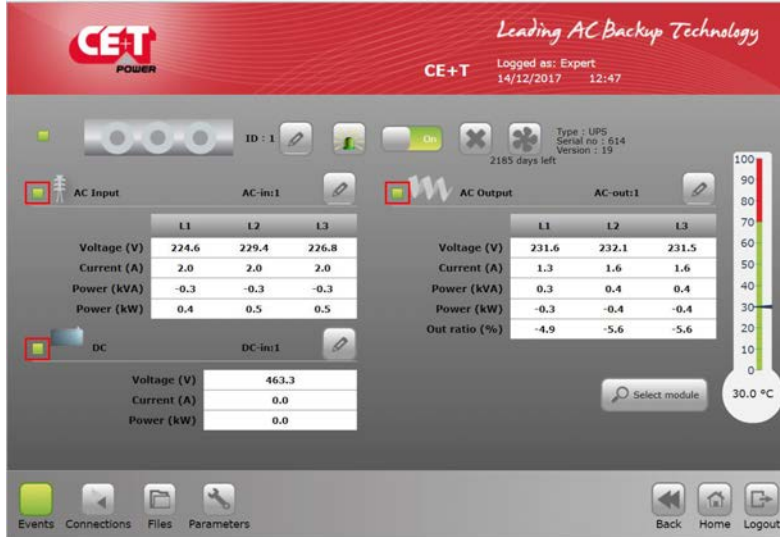



Table indicates the number of modules installed / not installed in the system.

Click on an installed module to access the specific information of the selected module.

Standard Features







Selected Module information

- Click "identify icon"  to see the corresponding module in the bay (all LEDs blinking).
- Module status indicated through the LED color on :
 - -AC input.
 - -DC input.
 - -AC output.

Green: OK.

Organe: Recoverable error.

Red: Non recoverable error.

	When a module is removed from the system, it must be uninstalled by clicking this icon.
	When fan is replaced in the module, the alarm "fan replaced" should be cleared by clicking this icon.
	Module can be switched off by software by clicking this icon. The current state (on or off) of the module is also given by this icon.
	Module AC-in, DC-in group and AC-out phase can be change by clicking this icon. Note: while changing the AC-out phase, the module should be in OFF condition.
	It will identify the current module in the system by clicking this icon. (All LEDs will blink in the module).

6.4 AC Output Load Sub-menu

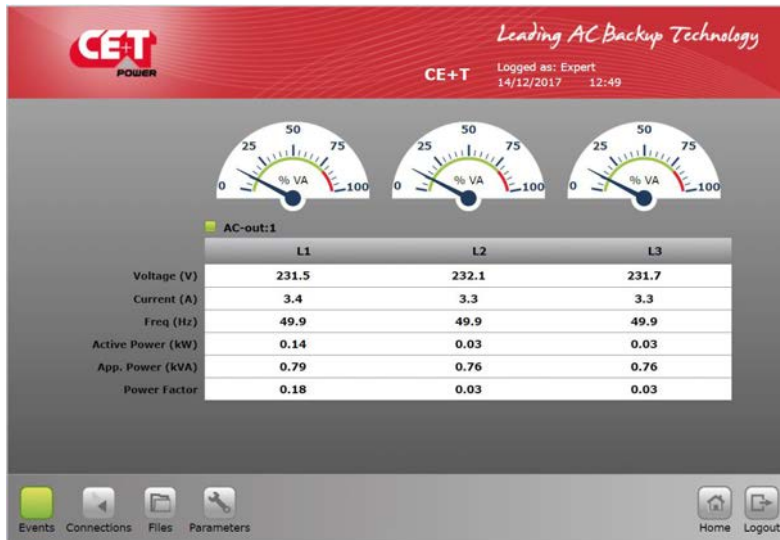

AC output control board

- Level of power bar graph.
- Measures: individual phase details of L1, L2, and L3
 - Voltage
 - Current
 - Frequency
 - Active Power
 - Apparent Power
 - Power Factor

6.5 SBP Modules Sub-menu

NB: This sub-menu is accessible only when there is at least one SBP installed in the system.

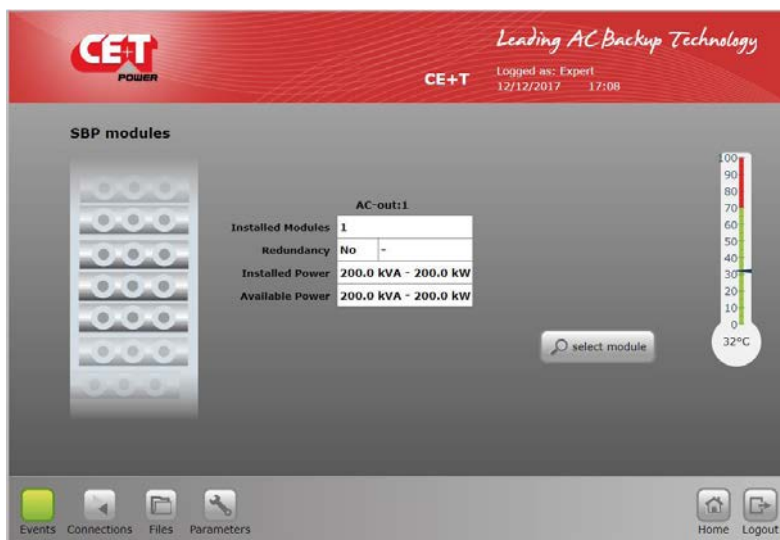

Provides SBP module info

- Number of module installed. (Maximum number of SBP can be installed in a system is 3 x 200 kVA)
- Redundancy level.
- Installed power.
- Available power.
- T° average of the module.

Standard Features

6.5.1 SBP Modules Sub-menu.







Clicking on the “Select Module” icon will open a module selection table.



Clicking on any line will give the view of the selected module.

While SBP engaged

- AC IN measures voltage and current
- AC Out measures apparent power and output ratio in percent.

	When a module is removed from the system, it must be uninstalled by clicking that icon.
	When fan is replaced in the module, the alarm “fan replaced” should be cleared by clicking this icon. Fan life expected remaining days are shown below this icon.
	Module can be switched off by software by clicking this icon. The current state (on or off) of the module is also given by that icon.
	Module AC-in group can be change by clicking this icon.
	To identify the current module in the system, click this icon to make it blink.

7. Toolbar



7.1 Events and Log

Please note “text alarm page” is refreshed every minute for easy reading while LED’s are active immediately.

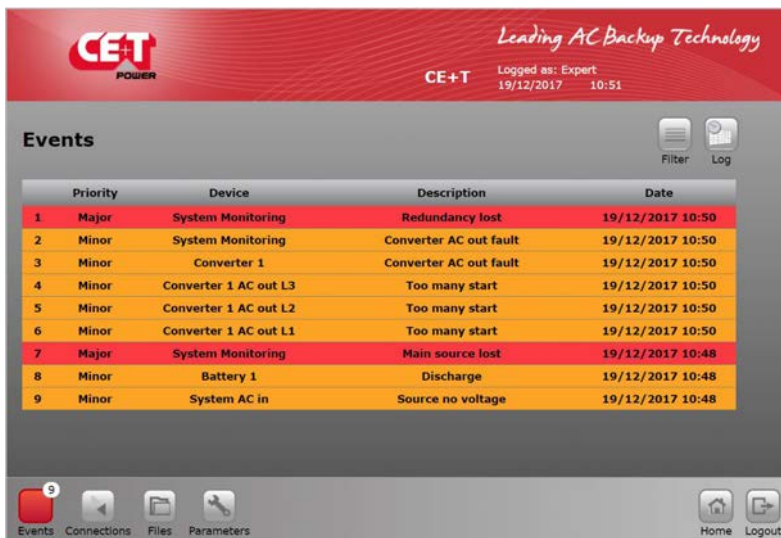

Priority	Device	Description	Date
1 Major	System Monitoring	Redundancy lost	19/12/2017 10:50
2 Minor	System Monitoring	Converter AC out fault	19/12/2017 10:50
3 Minor	Converter 1	Converter AC out fault	19/12/2017 10:50
4 Minor	Converter 1 AC out L3	Too many start	19/12/2017 10:50
5 Minor	Converter 1 AC out L2	Too many start	19/12/2017 10:50
6 Minor	Converter 1 AC out L1	Too many start	19/12/2017 10:50
7 Major	System Monitoring	Main source lost	19/12/2017 10:48
8 Minor	Battery 1	Discharge	19/12/2017 10:48
9 Minor	System AC in	Source no voltage	19/12/2017 10:48

Display the active event/alarm present on the system.

- Red: Major alarm.
- Orange: Minor alarm.
- White: No alarm.

Click on “Log” to view the history log file presented below

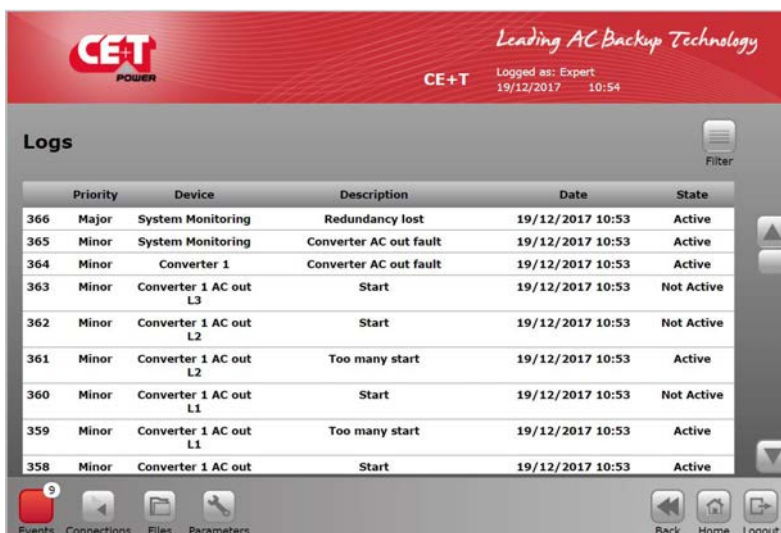

Priority	Device	Description	Date	State
366 Major	System Monitoring	Redundancy lost	19/12/2017 10:53	Active
365 Minor	System Monitoring	Converter AC out fault	19/12/2017 10:53	Active
364 Minor	Converter 1	Converter AC out fault	19/12/2017 10:53	Active
363 Minor	Converter 1 AC out L3	Start	19/12/2017 10:53	Not Active
362 Minor	Converter 1 AC out L2	Start	19/12/2017 10:53	Not Active
361 Minor	Converter 1 AC out L2	Too many start	19/12/2017 10:53	Active
360 Minor	Converter 1 AC out L1	Start	19/12/2017 10:53	Not Active
359 Minor	Converter 1 AC out L1	Too many start	19/12/2017 10:53	Active
358 Minor	Converter 1 AC out	Start	19/12/2017 10:53	Active

Log file can be filtered using the filter menu.

Toolbar



Do not forget to click apply to activated the selected filter.

Clear Filter will remove all selected filter and view all log file.

7.2 Input, output mapping

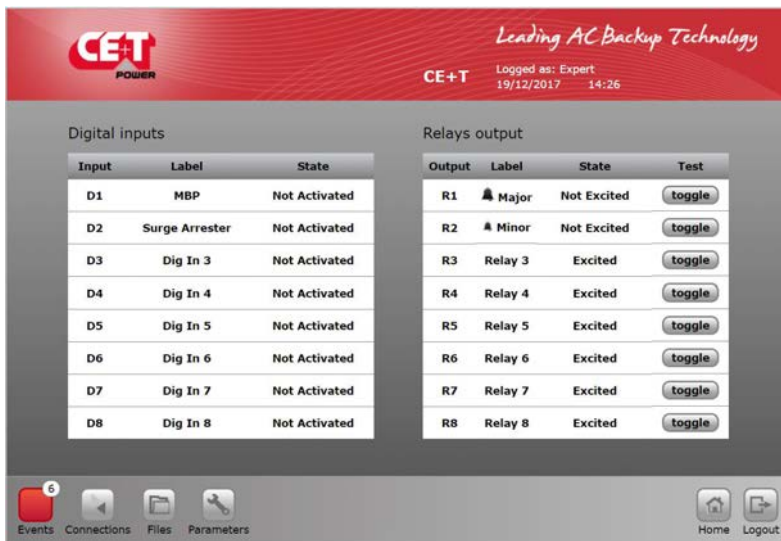

Present the output relay mapping with possibility to test each relay with the “toggle” button. Click and check relay chaging status with an ohmeter.

Note:

Only available in expert mode through laptop web browser.

7.3 Files

Transfer screen allow to export the log file and export or import configuration file



Transfer:

Event History

- Both Event log and configuration file can be exported.
- Event file name cet.log is a text format *.txt file.
- Log size limited to about 500 – 800 lines.
- Click on “clear” will erase the CET log file. Password protected.

Configuration:

- Configuration file can be exported or imported from the T4S.

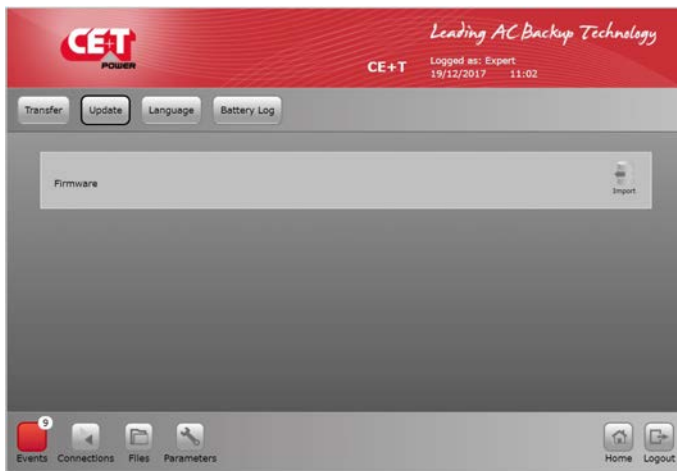

Update :

To upgrade T4S firmware. Import the file from computer and download to T4S.

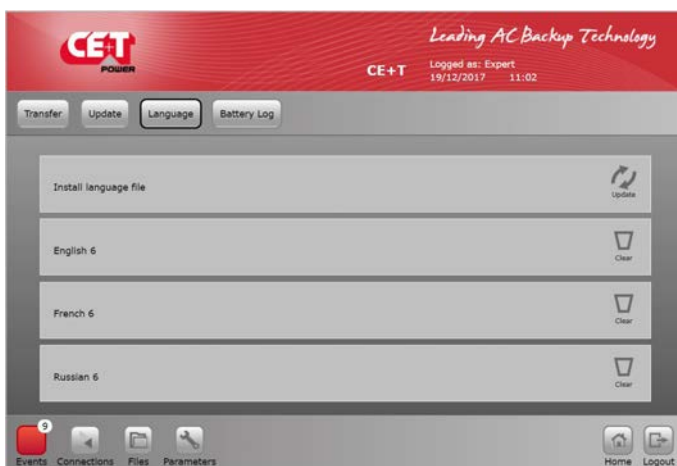

Language:

T4S store maximum 3 languages that can be changed, updated or cleared.



Battery Log:

To export or clear the battery log files.

7.4 Parameters

WARNING !

All values present are default values ! User shall consult and change default value with caution. Wrong parameters can affect the system operation, reliability, battery life duration and system autonomy.

7.4.1 Monitoring

NOTE: Once the new parameter has been entered click « save » to record the data otherwise the previous value will be retained.

This menu allow to Set time and region, Change password, Set Catena network parameter, Set Temperature sensor, and Define the alarm mapping.



Time

- Allow to set Time and Date.



Regional settings

- Choose language.
- Site name.
- Site Location.
- Auto logout delay (will disconnect user after defined seconds).
- Keyboard layout.

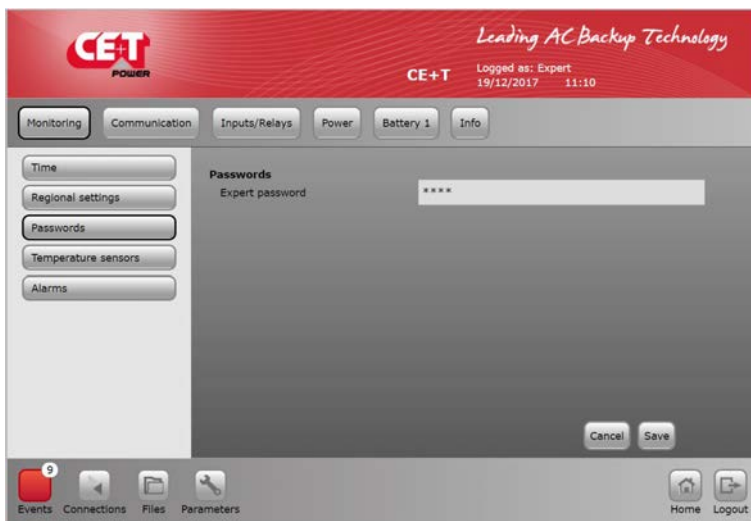

Password

Choose password. Read the information carefully at section 5.1, page 18.

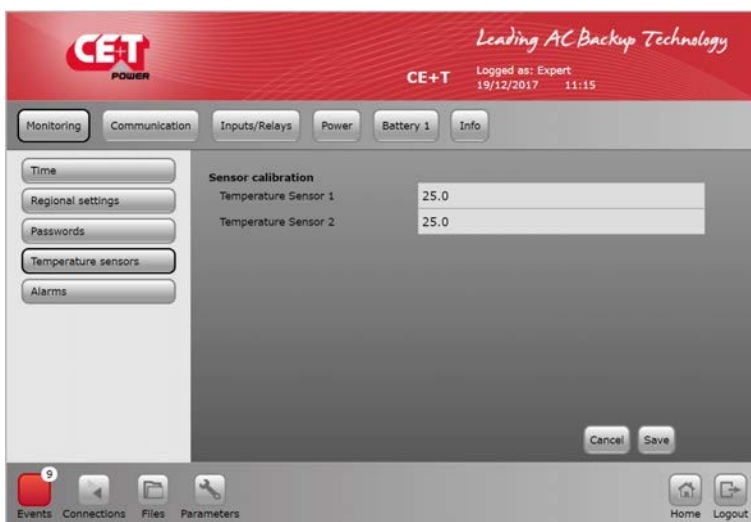

Temperature sensors

Allow to configure the temperature probe for battery compensation or ambient temperature.



Alarms

Allow to enable and disable the alarms.

7.4.2 Communication

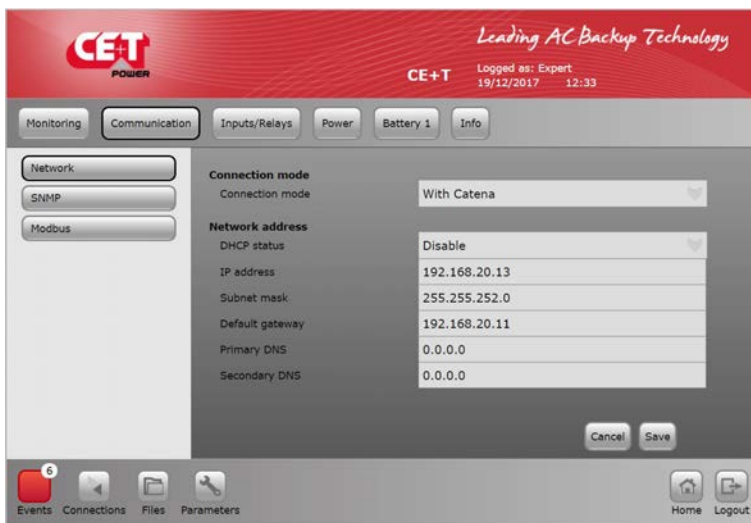

Network:

Allow to configure the LAN Network parameters

(Note: Default IP address is 192.168.0.2)



SNMP:

You can configure all SNMP and Trap related settings. For more details refer section 10, page 44.

Remark: Catena Network configuration is mandatory for having the screen working.

It should be on the same network as T4S.



Modbus:

You can view Modbus settings. For more details refer section 11, page 46.

7.4.3 Digital Input and output relay mapping

Inputs : Digital Input mapping =>mapping and assign a “name” to any of the 8 digital input. By default DG1 and DG2 are related to Manual By Pass if present and surge arrestor if present.

Toolbar



Input labels

- Allow to define a label that will be used for any digital input activated.
- Example
- Label 1 : Door open will report the event “Door open” every time the digital input 1 is active.

By default Digital Input 1 is assigned to “Manual By Pass” and Digital Input 2 is assigned to “Surge protection SPD” if it presents in the system.



Relay Label

Relay label define the text that will be used for output relay

Relay 1 and 2 are reserved for Major and Minor alarm. Relay 3 to 8 are free for any alarm definition

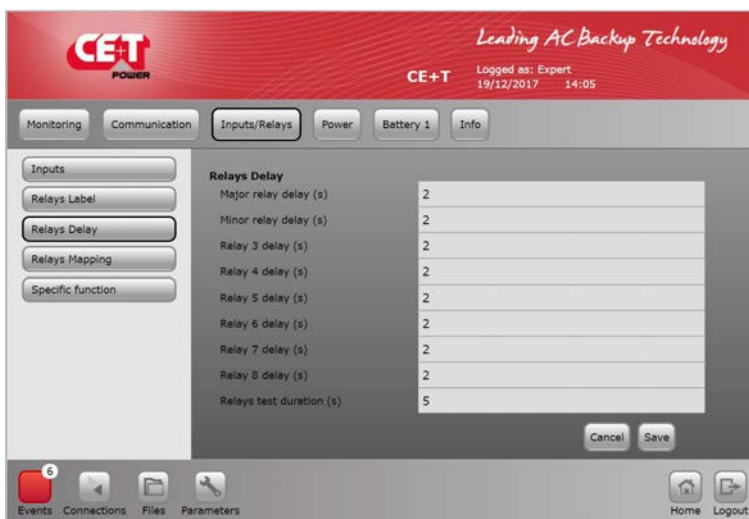

Relays Delay

Relays delay allow to define to delay in sec after which the relay will change status once the event has occurred.

Range from 2 seconds to 60 seconds.



Relay Mapping

Allow to perform the mapping of any alarm to any relay association.
One alarm can be allocated to more than one relays

7.4.4 Power parameter setting

The menu "Power" allow to perform the setting of the system, AC input, DC battery, AC output and Others.



General

To configure:

- Redundancy
- AC IN Groups and Phases
- AC Out Groups and Phases
- SBP function mode (Enable/Disable)



AC out

To configure AC output parameter AC out Phase sequence and AC out phase shift.

Nominal AC out frequency. If set different then AC input the BOOST will not be available

Frequency limit 30 to 70Hz.

Note: The parameter "Out voltage consign" set by default to 230 Vac shall be adjusted according nominal AC input voltage. This will limit the inrush current when operating on Smart By pass and Manual Bypass.

Note: The phase sequence must be respected between AC IN and AC Out. Improper phase sequence might damages equipment during MBP procedure.



AC In

To configure AC input Parameter.

- Phase shift (120° for 3 phase)
- Sync Priority: Define on which Phase - if all present – the module will synchronise the AC output.
- Low and High defined voltage to configure the voltage boundaries min and max from where AGIL will transfer to DC and vice versa.

DC group

To define min, max battery voltage for .Default value are related to 408VDC nominal battery (204 cells).



To configure DC input 1 Parameter.

Low and High define voltage to configure boundaries min and max from where AGIL will STOP to preserve battery from deep discharge.

Neutral connected:1 means the AC output is 3x400VAC + Neutral while 0 means the AC output is 3x400VAC without neutral. The load is 3phase without neutral.

Note:

If more than 1 battery, there will be 2 DC group for Battery 1 and Battery 2.

By default the AGIL config value are listed in the before screen

If those value need to be changed please respect the rules below:

(Number of cells x V float per cell) = Vdc ref the default value is described in section 7.4.5, page 37,
 $V_{ref} = 204 * 2,27 = 463.1 V$

$300V < V_{dc} \text{ low stop} \leq V_{dc} \text{ low transfer} < [20V \text{ hysteresis}] < V_{dc} \text{ low start} < V_{dc} \text{ ref} < V_{dc} \text{ high start} < [10V \text{ hysteresis}] <$

$V_{dc} \text{ high transfer} \leq V_{dc} \text{ high stop} < 495V$

Not respecting the rules above will result in parameters not accepted.

We recommend to proceed as below (respect the sequence):

To define the new value of **Low start voltage, Low transfer voltage, Low stop voltage** and save.

To define the new value for **Battery cells, Float voltage, Capacity, Current limit** in section 7.4.5, page 37, and save.

To define the new value for **High start voltage, High transfer voltage, High stop voltage** and save.

BATTERY type and capacity. To enter the data for charging voltage adjustment and T° compensation coefficient and T° compensation range where the compensation apply.

Other

- **Customer repartition:** 0 to 100% to define the ratio from AC in and battery.
0% - AC input as primary source.
100% - Battery as primary source.
- **Commutation time:** define the duration to return from DC to AC.
- **Synchro speed:** To define the speed for synchronization (**0** is a default value).
 - Fast Synchronization: **- 2**
 - Slow Synchronization: **+ 2**
- **AC reinjection:** Can select either Enable or Disable.
- **Vout min ovrl too long:** To define the value before alarm Over Load Alarm appear.
- **Delay ovrl too long:** To define the timeout to generate Over Load Alarm.
- **Triac enabled:** To define the BOOST function either Enable or Disable.
 - **Enable Boost:** If AGIL and SBP has same AC input source.
 - **Disable Boost:** If AGIL and SBP has two different AC input source.

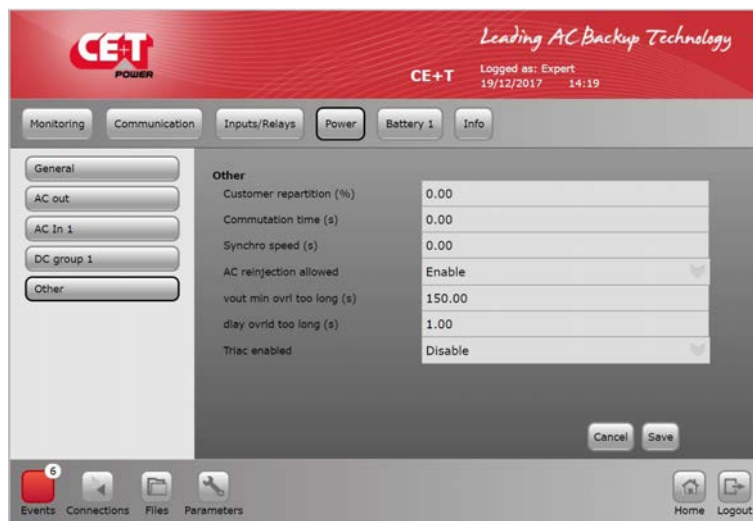

7.4.5 Battery 1 and Battery 2

Warning: !!!

Battery configuration is extremely important. There must be correct value entered for battery. Those parameter will define:

- The floating charging voltage;
- The boost charging voltage (if enabled);
- The current limitation to protect battery from overcharging current;
- The prediction of the battery capacity when battery test are performed.

Wrong value will affect the operation of the system and might have an impact on the battery lifetime.



General

Note: Configure battery. Refer to battery manufacturer for detail value.

- AGIL need always odd number as there is middle point. Ideal 204 cells (2V) min 180 max 228.
- Cell float V at 20°C
- Max current to limit during charging. Never exceed C10/4
- Cells capacity, If more then one string please multiply the cell capacity x number of string.



Temperature

Compensation

- Enter the value from manufacturer mV/°C
- Min: from where the compensation start
- Max: from where compensation stop



Test

- To set up the battery test parameter Power, time duration and voltage stop
- Auto test to define the periodicity of the test



Boost

To set up Boost, first enable it then set up the parameter

- Voltage per cell (from manufacturer)
- Boost can be activated on voltage value : Voltage start. After discharge below set volt per cell the boost will be activated or if
 - Boost can be activate on charging current value.
 - Boost can be activate periodically.

Boost stop always if the duration exceed the Stop value (seconds).



Alarms

- Cell Low voltage : End of autonomy alarm. AGIL will shut down very shortly by LVD
- Low Pre alarm : Pre-notification of low battery voltage
- Autonomy pre-alarm : Set the % of capacity available after the alarm
- Remaining capacity alarm % of autonomy available

7.4.6 Info



Info

Provide information about T4S

- Serial number
- Software version
- Interface version
- Bootloader version
- MAC Address

8. AGIL / SBP module and Fan replacement

8.1 AGIL / SBP module replacement

Caution:

Before sliding the module into the cabinet, make sure nothing is blocking the module such as objects, Catena wires and other wires.

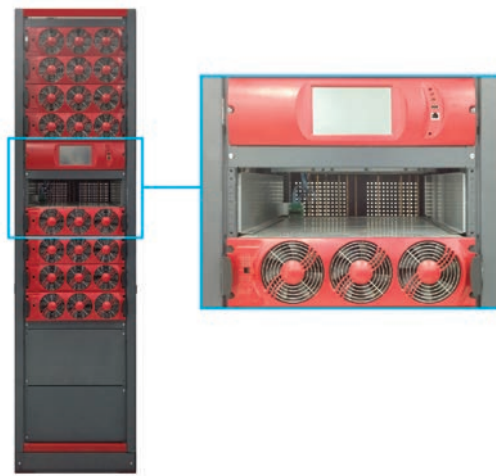

Step 1. Place the module in the cabinet.

Step 2. Using the front handle, slide in firmly until the module is properly engaged.

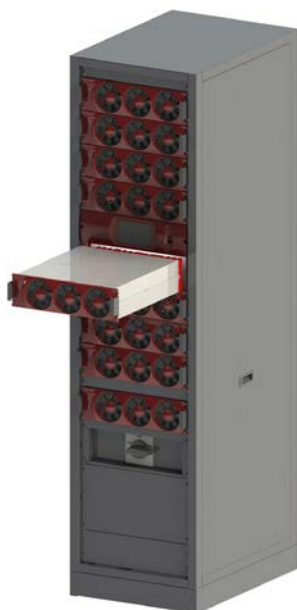

Place the module

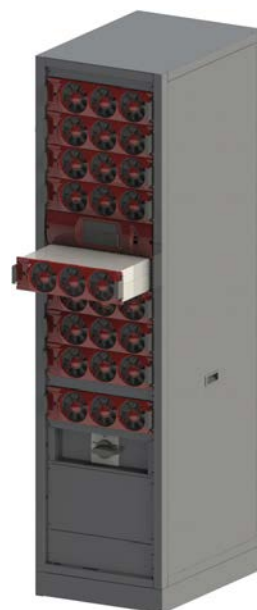

Slide in Firmly

8.2 Fan Replacement

The FAN pre-alarm “FAN life elapse” has been set to 5 years. An event will appear on the Catena to remind the “FAN life elapse”.

Perform the following steps to replace the AGIL Fan Kit:

1. Order and receive a replacement AGIL Fan Kit which consist of a metallic front plate on which the new three fans are already fixed (T451030001).
2. Remove the module from the system and let it rest at least five minutes prior to initiating the work.
3. Remove the **Front Red Plastic** by releasing all the five latches (3 latches at top and 2 latches at bottom) in the module.
4. Remove the **AGIL Fan Kit** (Front Metallic Plate) by unscrewing the eight screws.



Figure 1: Remove Front Plastic



Figure 2: Remove FAN Kit

5. Unplug the **Fan wires** from the terminal in the module.
6. Remove the **Synoptic Board** and **Mylar sheet** from the AGIL Fan Kit by unscrewing the four screws..



Figure 3: Disconnect the fan wires

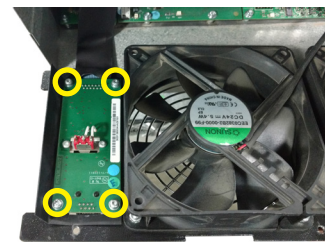

Figure 4: Remove Synoptic Board

7. Take the new **AGIL Fan Kit** (T451030001).
8. Fix the **Synoptic Board** into the new AGIL Fan Kit by using four screws, refer “Figure 4”.
Note: Place the Synoptic Board and Mylar sheet in exact position before tightening the screws.
9. Connect the **Fan wires** from AGIL Fan Kit to terminal in the module, refer “Figure 3”.
10. Fix the **AGIL Fan Kit** back in place by tightening the eight screws, refer “Figure 2”.
11. Fix the **Front Red Plastic** back in place, make sure all the five latches are fixed properly, refer “Figure 1”.
12. Insert the module in the system.
13. Once it has started, access the fan counter through the T4S/Catena and reset it (see page 22).

9. Factory Ranges and Defaults

Submenu Item	Programmable range	Default values 408Vdc
Float (FL) Voltage	408 – 490	463 Vdc
Equalize (BOOST) Voltage	408 – 490	480 Vdc (2,35V/per cell)
Test Batterie (BT) Voltage	315 – 490	391 Vdc
Battery current limit	0-1000	=C10/5 (Battery capacity/5)
Battery in discharge	315 – 490	430 Vdc
Battery Low 1 alarm	315 – 490	360 Vdc
Battery Low high	315 – 490	340 Vdc
System Saturation alarm	0 – 100	80%
Equalize Timeout	0 - 48	24 hours
Test Batterie Duration	0-8	8.0 hours

Submenu Item	Programmable range	Default values
Subnet Mask	N/A	255.255.255.0
Adress IP T4S	N/A	192.168.0.2

9.1 Definition

AC	Alternating current
DI	Digital Input
ALCO	Alarm cutoff
BCT	Battery current termination
BDT	Battery discharge test
BOD	Battery on discharge
BT	Test Batterie (mode)
CAN	Controller Area Network
DC	Direct current
DOD	Depth of discharge
EQ	Equalize (mode or voltage)
FL	Float (mode or voltage)
GUI	Graphical utilisateur interface
IP	Internet Protocol
LCD	Liquid crystal display
LED	Light emitting diode
LVA	Low voltage alarm
LVC	Low voltage connect
LVD	Low voltage disconnect
MAC	Media Access Control; p.e. MAC address
MIB	Management Information Base
OVP	Over-voltage protection
PPP	Point to Point Protocol
RAS	Remote access server
SCI	Serial Communication Interface
SNMP	Simple Network Management Protocol
TCP/IP	Transmission Control Protocol / Internet Protocol
Trap	Event notification

10. SNMP V1 & SNMP V3 Configuration

SNMP is now available on T4S supervisor and on Catena display.

SNMPv1 is available on T4S supervisor. The MIB implemented on T4S SNMP agent is the standard USP MIB defined by RFC1628.

Catena display now includes a SNMPv1 to SNMPv3 proxy.

The main difference between SNMPv1 and SNMPv3 is the addition of secured connection in SNMPv3.

10.1 SNMPv1 configuration

For SNMPv1 agent configuration, go to Parameters > Monitoring > Network.

See [T4S network section for ETH port configuration](#):

- IP address.
- Subnet mask.
- Gateway.

See [T4S SNMP section for SNMP agent configuration](#):

- Trap receivers IP addresses. Up to 5 trap receivers can be configured.
- Note that ports 161 and 162 (for traps) are used. Not configurable.

10.2 SNMPv1 MIB (RFC1628)

The MIB is the standard UPS MIB defined by RFC1628.

Meaning of “input lines”: input lines are AC input groups as existing in T4S web interface. One tri-phase system will have 3 input lines, one for each phase.

Meaning of “output lines”: output lines are AC output groups as existing in T4S web interface.

The following features of UPS MIB are not implemented in T4S:

- Writable entries. The current MIB is read-only. Entries can only be edited through the web server. For this reason, the upsConfig section is also read-only.
- Bypass values. As T4S doesn't include the monitoring of bypass devices, bypass measurements are not available in the MIB. It is however possible to know when the system switched to MBP by reading ups Output Source value (OID .1.3.6.1.2.1.33.1.4.1).
- Well known test. Only standard battery test is available. No other test is implemented in T4S at current state.

Any feature defined in RFC1628 that is not in the previous list is available.

10.3 SNMPv3 configuration

For SNMPv3, you need a Catena display. The Catena display can be used as SNMPv1 to SNMPv3 proxy.

The configuration of Catena display is managed by T4S supervisor.

In T4S web interface, go to Parameters > Monitoring > Network.

SNMP V1 & SNMP V3 Configuration

See Catena network section:

Set IP address, subnet mask, and gateway for local network.

Set “bridge enable” option. By default, both ETH ports of Catena are in the same LAN. If the bridge is disabled, then each port is on an independent LAN.

If bridge is disabled, set IP address, subnet mask, and gateway for external network.

If bridge is disabled, the most outward ETH port is connected to the local network, and the most inward ETH port is connected to the external network. The T4S must be on the local network.

Please note that SNMPv1 agent and T4S web server have no security. For a secure connection, it is strongly recommended to use SNMPv3 interface only (T4S on local network and bridge disabled).

See Catena SNMP section:

SNMPv3 context can be configured.

SNMPv1 agent community can be configured. Not used for now since T4S agent community is not configurable (public by default).

Three users can be configured:

- Read-only user. There is no authentication and no encryption. No other parameter than user name is required.
- NoPriv user. This user is authenticated but there is no encryption. Authentication protocol (MD5 or SHA) must be selected. Authentication password must be configured.
- Priv user. This user is authenticated and connection is encrypted. Authentication protocol (MD5 or SHA) must be selected. Authentication password must be configured. Encryption protocol (DES or AES) must be selected. Encryption key must be configured.
- A user can be completely disabled by setting an empty user name.

Base OID's have to be configured for each user.

One trap received can be configured:

- Trap received IP address.
- Engine ID.
- Security level. You can select if the trap will use both authentication and encryption, only authentication, or none.
- Trap authentication password. Only required if authentication is enabled in security level option.
- Trap authentication protocol (MD5 or SHA). Only required if authentication is enabled in security level option.
- Trap encryption key. Only required if encryption is enabled in security level option.
- Trap encryption protocol (DES or AES). Only required if encryption is enabled in security level option.

11. ModBus RTU

T4S can act as a ModBus RTU slave with various baud rates and configuration options. No action can be done on the system through ModBus port; it's only for monitoring purposes.

11.1 Physical Connection

To get access to the ModBus, the RJ45 labeled "RS485" on T4S monitoring unit should be connected. RJ45 pinout is as follow:

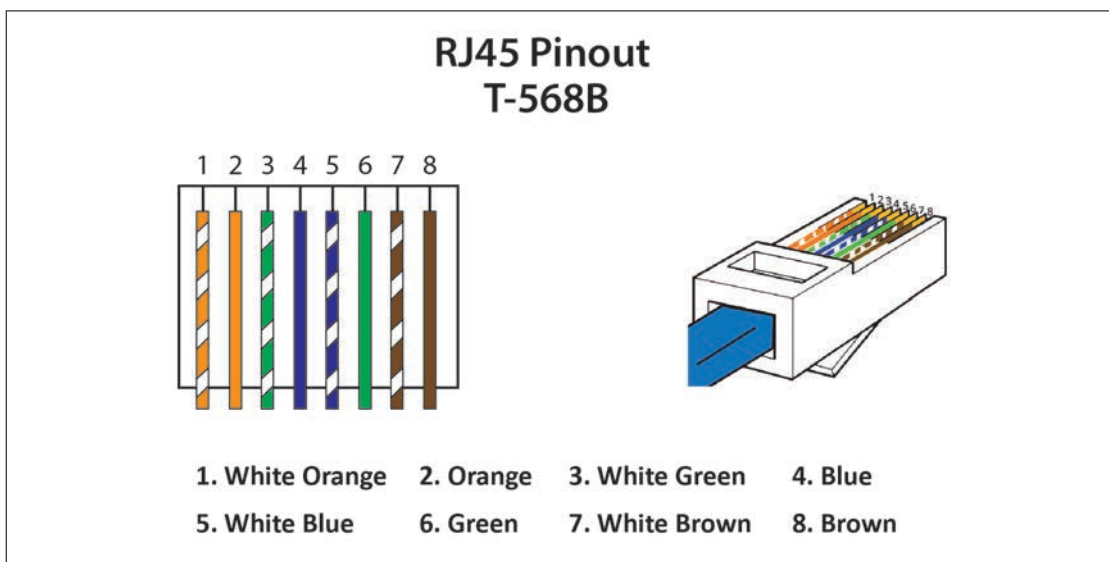

Note: The colour of wires is irrelevant and may vary, but make sure the position of wires is exactly crimped.

- Pin 4 = D1
- Pin 5 = D0
- Pin 8 = Common (GND)

11.2 Configuration

ModBus slave configuration is accessible through user interface by browsing menu *Parameters, Monitoring Tab, ModBus* submenu.

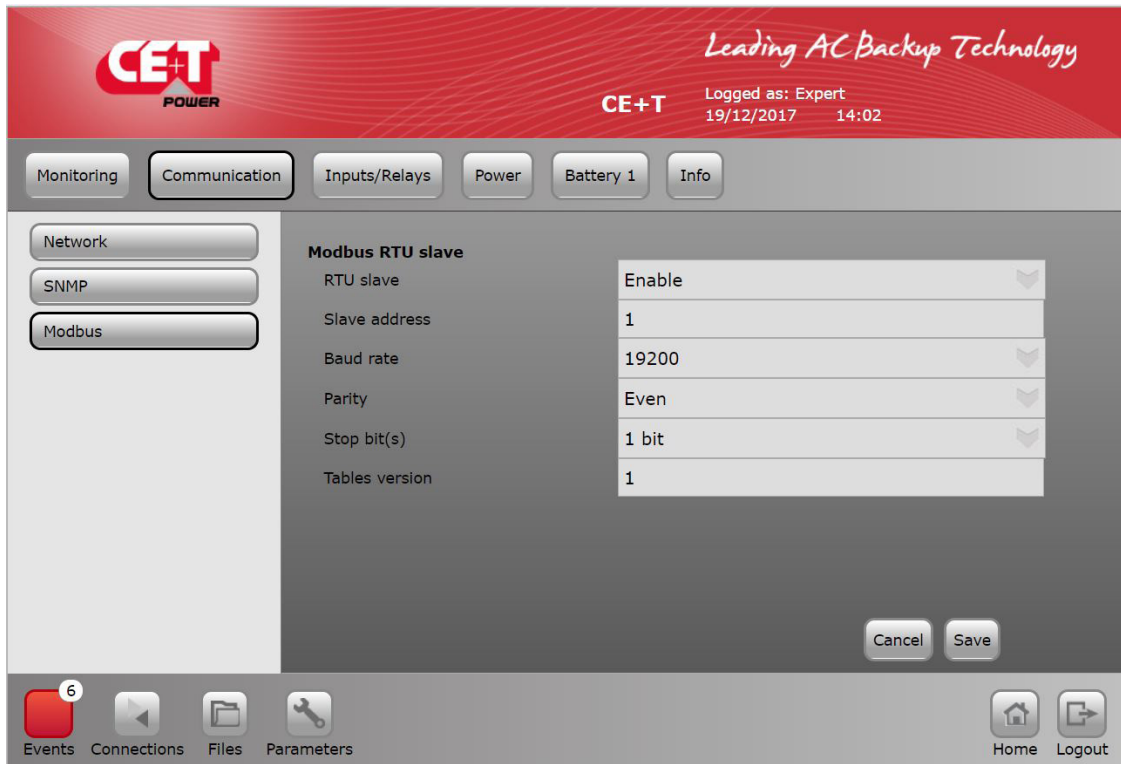

- Modbus RTU slave can be either *enabled* or *disabled*.
- Slave address ranges from *1* to *247*. Default is *1*.
- Supported baud rates are: *9600, 19200, 38400, 115200, or 460800*. Default is *19200*.
- Parity can be *none, even, or odd*. Default is *even*.
- Stop bits can be *1* or *2*. Default is *1*.
- Configuration is applied once *save* button is clicked.

Table version parameters ensure that customer can use any revision of the modbus tables he wants. First release is based on table revision 1.

11.3 Tables

Data are organized in tables which are described in another document called *T4S_Agil_ModBus_Tables.pdf*

ANNEXE 1. Battery Management with AGIL Technology and T4S

1.1. Introduction

Battery is critical element in a UPS. Many manufacturer offer high performances of their electronic but sometimes forgot about providing an efficient and reliable battery management.

Battery are fragile and need to be treated accordingly in discharge and recharge conditions. The purpose of this document is to provide an overview of how TSI and AGIL manage the batteries, prevent their end of life and reduce possible occurrence of thermal runaway.

1.2. CE+T Battery charging and discharging MODE

The purpose of a charger is to “refill” the charge tank of the battery. There are many other features which enhance the convenience of the charger, or grant protection for the battery being charged. These built-in protection features is what fundamentally elongates the battery’s life, or more correctly, prevents premature failure.

TSI technology provide those features:

- higher current levels reduce recharge times (assuming the battery can accept charge at high rates).
- voltage limits, current limits, and time out to reduce excessive gassing at end-of charge, and prevent dry-out.
- modified voltage and current limits as a function of temperature reduce gassing and electrode damage.
- BOOST or Equalize mode to equalize battery blocs periodically

CE+T AGIL and controller T4S battery operating mode are described below

1.2.1 MODE 1 BOOST

This mode need to be activated and configured according the battery data from the manufacturer

A CCCV (constant current, constant voltage) algorithm to provide a “quick an fast recharge. Ideally to recover 80% of the battery capacity in maximum 8 hours. This mode use a U_{set} voltage level associated to current limit protection

Figure 1. Typical recharge curve versus time for voltage and current.

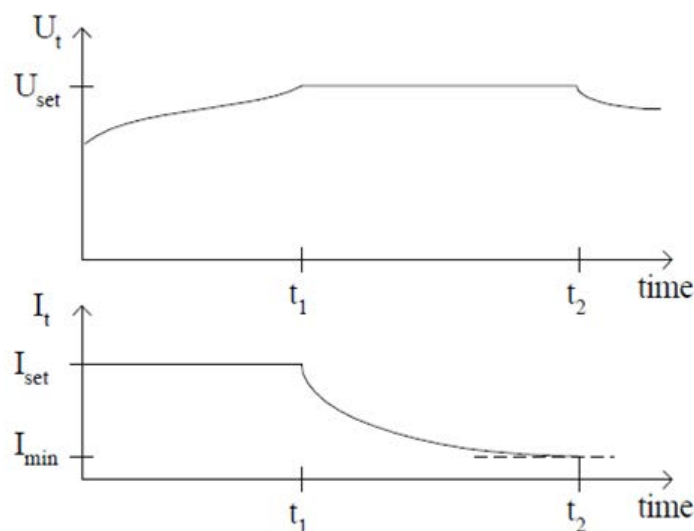

Battery Management with AGIL Technology and T4S

MODE 1 algorithm can be trigger based on the following parameter:

- Trig Start Voltage : Will activate MODE 1 when battery voltage goes below preset level
- Trig Start Current : will activate MODE 1 when battery current goes above the preset value
- Trig Start Period : Will activate MODE 1 periodically base on preset value.
- Manual Start : Will activate MODE 1 manually through the GUI menu

In mode 1 the temperature compensation is disabled.

MODE 1 algorithm can be stopped based on the following parameter :

- Trig Stop Current: Will stop MODE 1 when battery voltage goes below preset level and MODE 1 for minimum 5 minutes (to avoid successive Start and Stop)
- Trig Stop Duration: 1H to 48H will stop MODE 1 (always active) will stop the MODE1 after the duration.

Note: If MODE1 stop based on “duration” before the “Stop current” reached an alarm will be generated as the battery need to be checked.

- Trig Start Period: Will activate MODE 1 periodically base on preset value.
- An alarm appear in the system: MODE 1 will be disabled in case of alarm presence
- Manual stop: will STOP MODE 1 manually through the GUI menu

1.2.2 MODE 2 FLOAT:

This is the normal operating mode for maintaining the battery in charge. This mode is enabled by default

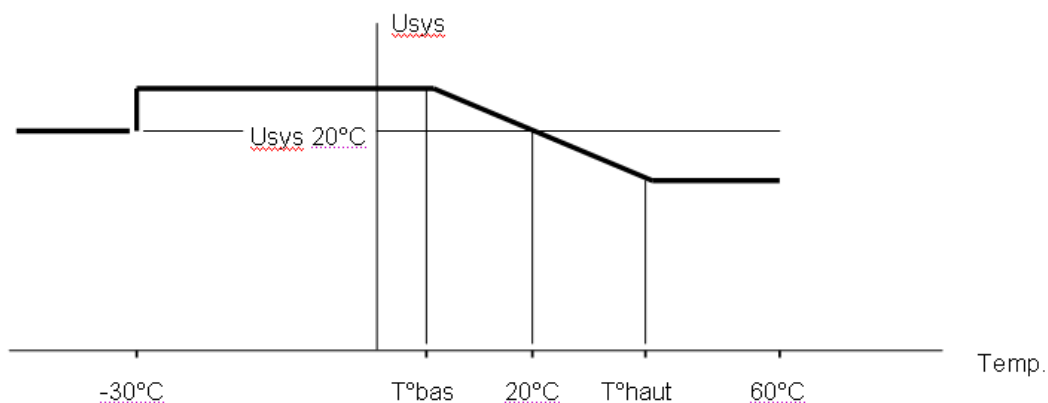

The MODE 2, charging voltage is adapted (provided it is enabled in the configuration) according the temperature. Using the charging curve below.

T° bas-low and T° haut-high are adjustable

Note : If the temperature probe is disconnected or defective the voltage will come back to the value at 20°C . An alarm “ T° sensor fail” will be generated.

1.2.3 MODE 3 Discharge

Discharge mode is active when energy flow is taken from the battery to the DC/AC converter (inverter) of each module.

In this mode the T4S monitoring sent a voltage and current value to the AGIL module. This help in case of one module has AC input failure to take power from DC and is feed through the other module to avoid discharging the battery and assure the continuity of supply for the AC load.

Following alarms and time out available:

- Ubat < Ufloat
- BAT cell V low
- BAT end of autonomy
- BAT discharge time out (Battery in discharge for more than xx minutes)
- V BAT stop : AGIL will stop operating to prevent deep discharge

Note: During discharge, T4S will record battery discharge value

1.2.4 MODE 4 BATTERY TEST

Battery test is a helpful function to get reliable information on the battery conditions and capacity.

It is recommended to perform periodic test of the battery but more important to perform those test in the same conditions in order to obtain comparative data over the years of the battery lifetime.

Starting BATTERY TEST conditions:

- Manual
- Trig Start Period: Specify the day of the week to perform the periodic test and the number of weeks between 2 tests.

Note: Periodic test will start only if no discharge during last 96 hrs to guarantee the same start conditions for every test.

Stopping BATTERY TEST conditions:

- Trig Stop Duration : always active. Define the maximum time duration of a test
- Trig Stop Voltage : stop the test when battery voltage reaches the preset value
- An alarm appears in the system:
 - AC IN failure
 - Module failure
 - V BAT too low
 - System Overload
- Manually through the GUI menu

Note: During any test or battery discharge the following data will be recorded.



Leading AC Backup Technology

Battery Management with AGIL Technology and T4S

START BAT x TEST + data and time

FIN BAT x TEST + data and time

For every delta of 1VDC record of:

- Date in seconds
- Battery voltage
- Battery current
- Bat Temperature

END BAT TEST + date+Time, VBAT, Temp+ Success, FAIL

START BAT x DISH + data and time

FIN BAT x DISH + data and time

For every delta of 1VDC record of:

- Date in seconds
- Battery voltage
- Battery current
- Bat Temperature

END BAT DISH + date+Time, VBAT, TEMP

ANNEXE 2. AGIL Manual Bypass (MBP)

The purpose of this document is to provide guidelines for customers to implement, assemble, wire and test external manual by-passes using CE+T AGIL modular UPS' with T4S monitoring units.

The CE+T delivered cabinets equipped with manual by pass are not concerned by this document.

2.1. Introduction

The purpose of the Manual Bypass also named “service by pass” is to provide the capability to completely by-pass the modular UPS AGIL system and SBP in order:

- To perform service maintenance to the equipment
- To externally by-pass the UPS installation and allow the removal of the equipment

2.2. Principle of operation

The manual by-pass (MBP) is a “make before break” Bypass manual switch.

The MBP can be in 3 position mode:

- OFF or NORMAL:** The MBP is not engaged (OFF) and the USP normally feeds the critical load.
- INTERIM or TRANSFER:** The MBP is in a temporary interim position where the AC load is supplied through the manual by-pass. The AGIL UPS is in start up mode and not yet connected to the AC output.
- ON or BY PASS:** The MBP is engaged, the AC input feeds the AC load, the UPS modules are OFF. Disconnect DC source to turn OFF the system completely. (Note: AGIL Module auxiliary power supply and monitoring are still power up by DC source once MBP is engaged)

Warning: If MBP is engaged, the neutral connection is not isolated and not voltage free.

Block wiring of the MBP

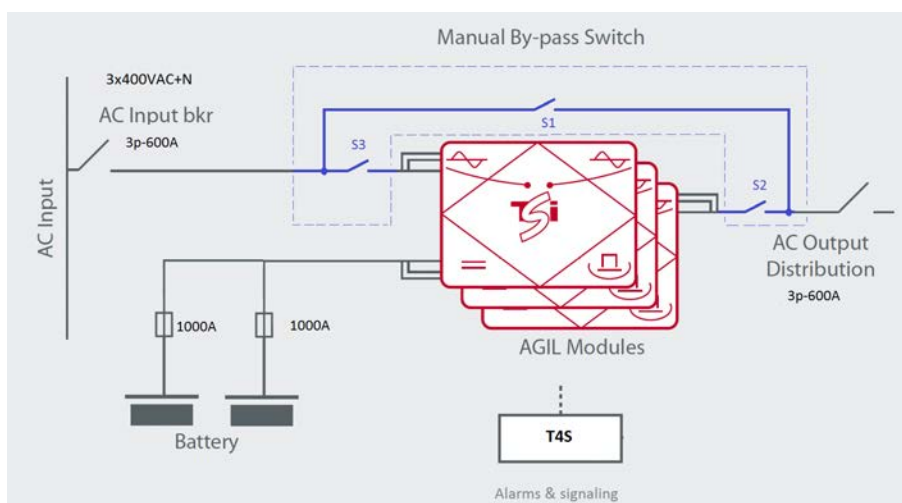

NORMAL mode or OFF: S1 is open, S2 and S3 are closed

INTERIM or TRANSFER: S1 is closed
S2 and S3 can be in position OPEN or CLOSED depending where you are in the manual by pass procedure

Note: This position is only temporary. It is used to allow the modules to start up and synchronize with the AC input. The user should not keep the Bypass in the INTERIM position.

BY-PASS mode or ON: S1 is closed. S2 and S3 are open.

2.3. Presentation

The Manual By-pass can be provided with 2 executions:

1. Rotary Switch for AGIL 60 kVA and AGIL 160 kVA

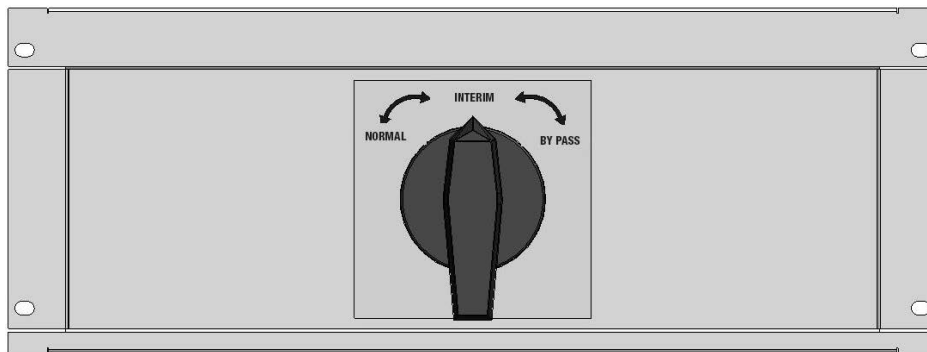

2. Two (2) power switches external to the AGIL cabinet for power above 160 kVA

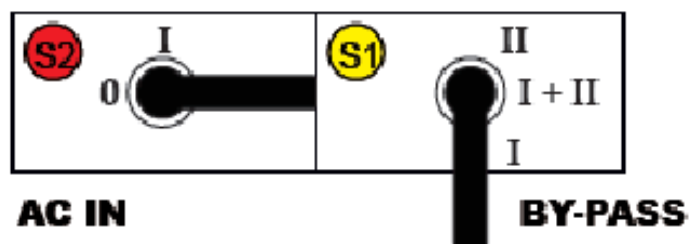

Please refer to the AGIL installation manual for more specific procedures.

2.4. MBP Wiring

Both solutions (rotary by-pass or separate switches) need to have auxiliary contacts that need to be wired to the monitoring unit as described below and as shown on the drawing present in annexe

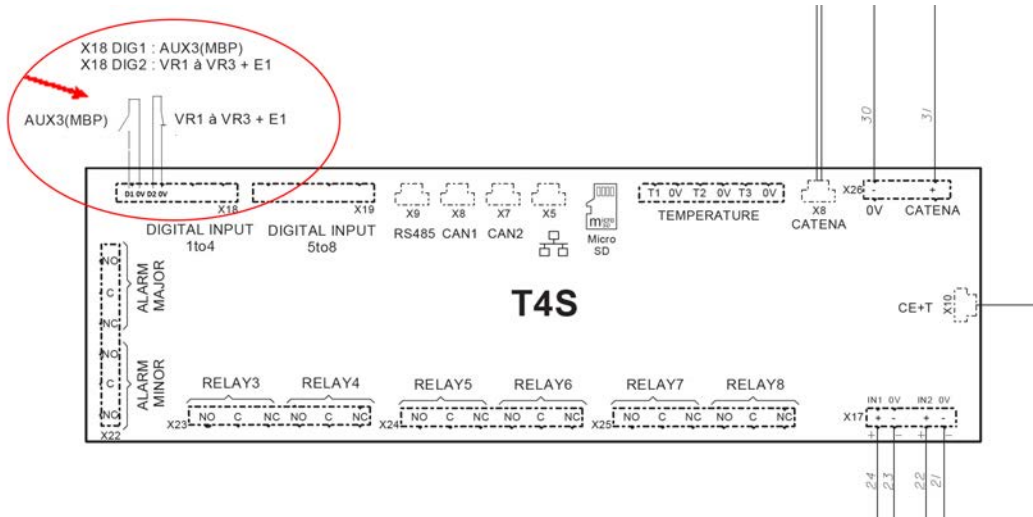

Aux 3 (from the by pass switch) : Provides an input to the controller indicating that the MBP is engaged

Aux 1 (From AC input switch) and Aux 2 (from the by pass SWITCH):

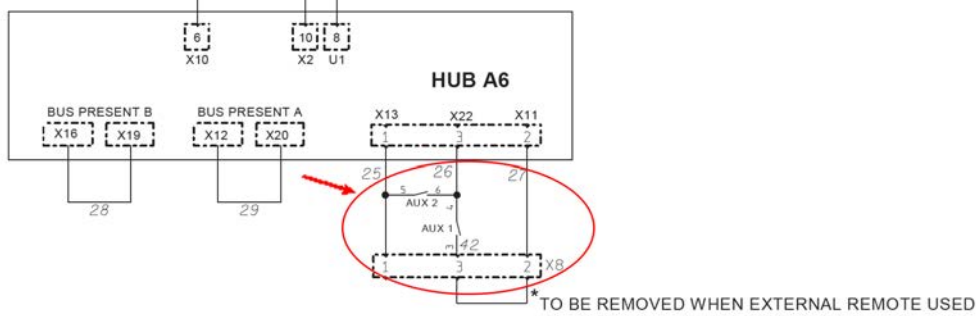

- Switch OFF the AGIL modules once the MBP is engaged.
- Allow the AGIL modules to switch ON when the MBP placed in the INTERIM position.

Note:

The parameter “Out voltage consign” set by default to 230 Vac shall be adjusted according nominal AC input voltage. This will limit the inrush current when operating on Smart By pass and Manual By pass.

ANNEXE 3. AGIL Smart By-Pass (SBP)

The purpose of this document is to provide guidelines for customers to access the Smart By Pass using CE+T AGIL modular UPS' with T4S monitoring units.

Note: SBP should be installed and operated only in AGIL UPS System.

Caution: If AGIL and SBP has two different input source, it is mandatory to disable the Boost function. Refer "Triac enabled" parameter at section "Other", page 36.

3.1. Introduction

The purpose of the Smart By-Pass is to provide the capability to completely by-pass the modular UPS AGIL system in order:

- SBP will transfer the Load to Bypass without interruption.
- To perform service maintenance to the equipment.
- To externally by-pass the UPS installation and allow the removal of the equipment.

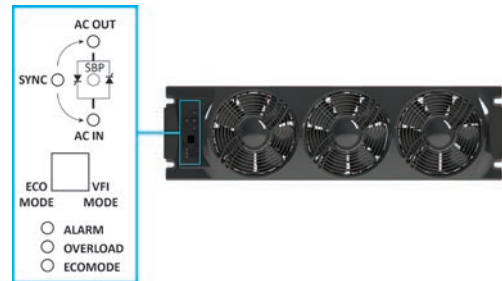

3.2. Principle of Operation

The SBP can be in two positions mode :

OFF or NORMAL: SBP is not engaged (OFF) and the UPS normally feeds the critical load.

ON or BY PASS: SBP is engaged, the AC input feeds the AC load, the UPS modules are OFF.

Warning: If SBP is engaged, the neutral connection is not isolated and not voltage free.

Note: The parameter "Out voltage consign" set by default to 230 Vac shall be adjusted according nominal AC input voltage. This will limit the inrush current when operating on Smart By pass and Manual By pass.

The image at right is the Block diagram of the SBP with AGIL and MBP

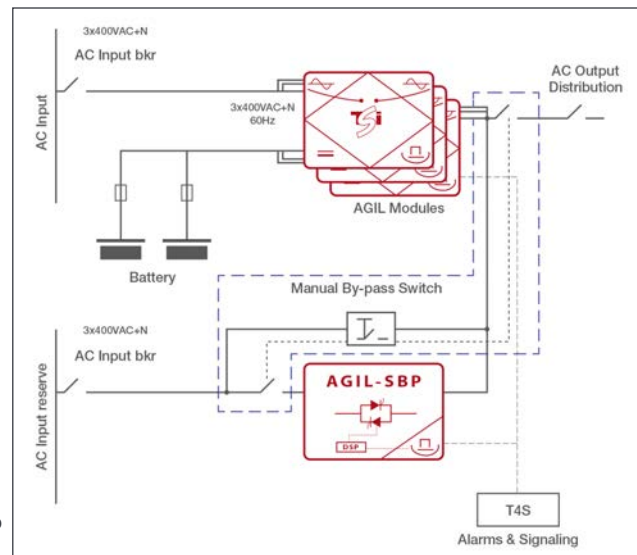

3.3. SBP LEDs Indication

LEDs in SBP indicates the status of AC Input, AC Output, SYNC, SBP, Alarm, Overload, and Ecomode.

The following image illustrates the status of:

- SBP Engaged.
- SBP Ready.
- SBP Input Not OK.

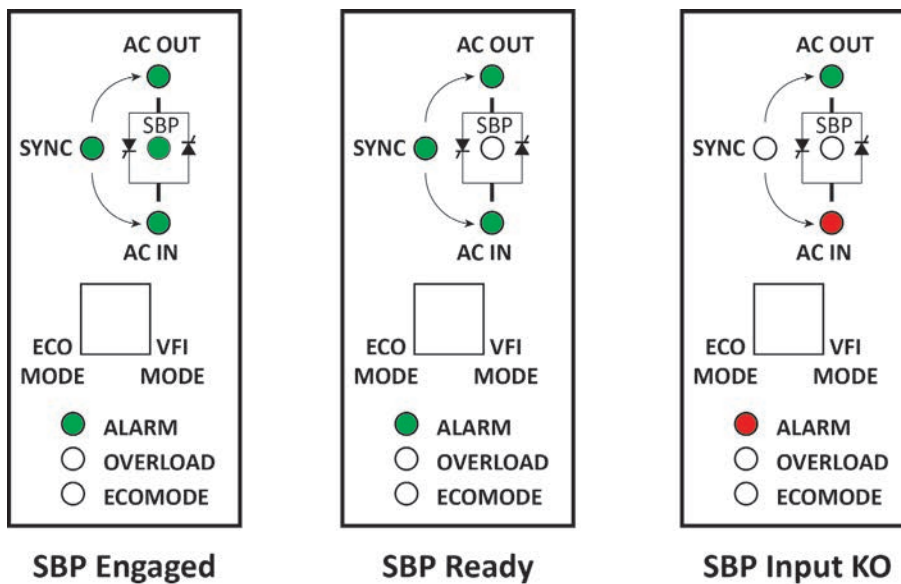

3.4. SBP Breaker Selection

SBP Upstream and Downstream breakers are depends upon the number of AGIL Modules installed in the system.

Model		AGIL 60	AGIL 160	AGIL 200	AGIL 380	AGIL 580
Capacity	AGIL Max System Power (kVA)	60 kVA	160 kVA	200 kVA	380 kVA	580 kVA
	Each AGIL Module capacity	20 kVA				
	Each SBP Module capacity	200 kVA				
	SBP Max System Power (kVA)	1 x 200 kVA			2 x 200 kVA	3 x 200 kVA
AC Input/ AC Output	Rated current (A)	90	231	289	552	842
	Breaker / Fuse (A)	125	315	400	630	1250
	cable mm ²	35	95	150	2 x 150	3 x 150
PE	Cable mm ²	35	95	150	2 x 150	3 x 150

ANNEXE 4. T4S Alarms

4.1. Supervisor alarms: T4S

This is the list of alarms issued by supervisor. Other alarms are issued by modules directly (see AGIL alarm table & OCA document). The supervisor is able to generate alarms that are related to the system, to AGILs modules, or to itself. Alarms related to AGILs will be seen as system alarms when module alarm is present on all AGILs.

Each alarm has a priority level. The level can be {disabled, event, minor, major}. If the level can be configured in user interface, then it is marked as “mappable”, please refers to the last table for standard mapping.

Monitoring Alarms				
Text ID	Name	Level	Def. Map	Description/ Possible action
224	MBP engaged	Mappable	/	The system is in manual by pass mode. Disengaged MBP to recover normal mode
225	Surge arrester	Mappable	/	Surge protection trip. Check & replace surge protection device
226	Redundancy lost	Mappable	/	The defined redundancy for a group is lost. According to config replace or restart faulty module
227	System saturated	Mappable	/	Load power is above the defined level (settable in Saturation threshold parameter). Check load level and add modules if possible or change parameter level
228	Main source lost	Major	/	Depending on the configuration, the AC input power source is missing. Check AC input breaker or source presence
229	Secondary source lost	Minor	/	The DC source (battery) is not present or end of autonomy. Check battery fuse or voltage
230	System overloaded	Mappable	/	The load power is above 100% of the system capacity
231	Log nearly full	Event	/	The number of events in the log file is above 80% of the maximum number of events
232	Missing converter	Mappable	/	A module is not seen on the bus. It can be bus failure at module level. Unplug module and replug. If problem still present module need to be replaced
233	Aux power supply fail	Minor	/	One of the two power supply of the T4S is lost. Check auxiliary power supply
234	New module	Event	/	A new module is seen on the bus, it will be installed by the system automatically
235	Log cleared	Event	/	The log file has been cleared
236	Config modified	Event	/	This temporary event appears to confirm the modification of some parameters
237	System started	Event	/	The system started and is in normal operation
238	DigIn 3	Mappable	/	The digital input 3 is active (NO or NC depending of the configuration)
239	DigIn 4	Mappable	/	The digital input 4 is active (NO or NC depending of the configuration)

Monitoring Alarms				
Text ID	Name	Level	Def. Map	Description/ Possible action
240	DigIn 5	Mappable	/	The digital input 5 is active (NO or NC depending of the configuration)
241	DigIn 6	Mappable	/	The digital input 6 is active (NO or NC depending of the configuration)
242	DigIn 7	Mappable	/	The digital input 7 is active (NO or NC depending of the configuration)
243	DigIn 8	Mappable	/	The digital input 8 is active (NO or NC depending of the configuration)
244	Monitoring started	Event	/	The T4S/CATENA has restarted
245	Log full	Minor	/	The log file has reach the maximum number of events. More events will not be recorded anymore
246	Converter off	Minor	/	The given module is off manually or remotely.
247	Converter AC out fault	Mappable	/	The given module has ACout problem. Module need replacement and repair
248	DigIn 1	Mappable	/	The digital input 1 is active (NO or NC depending of the configuration)
249	DigIn 2	Mappable	/	The digital input 2 is active (NO or NC depending of the configuration)
250	Redundancy +1 lost	Mappable	/	Means that the system has lost one module more than the configured redundancy for a group. Means that this groups could be overloaded.
251	Missing SBP	Mappable	/	A SBP is missing in the system.
252	SBP AC out fault	Mappable	/	Problem in SBP Acout. Module need replacement
253	SBP engaged	Mappable	/	System is running on Smart By Pass
254	Time synchronized	Event		Time synchronization through digital input occured
255	MBP procedure	Mappable		System with SBP is in MBP procedure
256	Battery charge remote off	Mappable		Battery charging is disabled through digital input
512	Discharge	Mappable	/	Battery is discharging.
513	Charging failure	Minor	/	Battery cannot be charged.
514	Boost in progress	Mappable	/	A boost charge is in operation on BAT1 or BAT 2
515	Test in progress	Mappable	/	A battery test is in operation on BATTERY 1 or BATTERY 2
516	Defect	Minor	/	Problem detected on a battery 1 o 2 after battery test
517	Low voltage pre	Minor	/	Battery voltage has reach the settable pre-alarm level
518	Low voltage	Mappable	/	Battery voltage has reach the settable alarm level
519	End autonomy	Mappable	/	The battery voltage has reach the settable end of autonomy level

Monitoring Alarms				
Text ID	Name	Level	Def. Map	Description/ Possible action
520	Low capacity pre	Minor	/	Battery capacity is in pre-alarm condition
521	Low capacity	Minor	/	Battery capacity is in alarm condition
522	No more autonomy	Mappable	/	Battery has reach its lower level, DC converter will soon stop
523	Overvoltage	Mappable	/	Battery is in overvoltage alarm
524	Unknown capacity	Minor	/	At startup, the battery is in unknown capacity state, the supervision system will soon detect the capacity
525	Temperature sensor fail	Mappable	/	Battery temperature sensor fail appears when the probe is disconnected
526	Over temperature	Mappable	/	Battery T° is above configured limits
527	Limited charging	Minor	/	The charger limits current to the battery according parameter.
528	Boost too long	Minor	/	Means that a boost charge of the battery exceed the specified time out. Please check battery is healthy
529	Low remaining time	Minor	/	The battery remaining time is low
530	Test: manual stop	Minor	/	Means that a test has stopped due to user manipulation
531	Test: recent discharge	Minor	/	A test will not start because battery has been in discharge within 96 hours
532	Test: voltage low	Minor	/	A test will not start because the voltage is too low
533	Test: system alarm	Minor	/	A test will not start because there is an alarm that prevent the battery test to start
534	Test: already in boost	Minor	/	A test will not start because the battery is already in boost charge.
535	Test: charger OFF	Minor	/	A test will not start because the charging is disabled and so the battery will not be charged after the test.

Mappable Events (Not alarms !!)				
Text ID	Name	Level	Def. Map	Description
632	AC in failure	/	Major + R3	
633	AC out 1 failure	/	Major	
634	Battery 1 discharge	/	Major	
635	Battery 2 discharge	/	Major	
636	Battery 1 low	/	Major	
637	Battery 2 low	/	Major	
638	Digital input 1	/	Event	
639	Digital input 2	/	Event	

Mappable Events (Not alarms !!)				
Text ID	Name	Level	Def. Map	Description
640	Digital input 3	/	Event	
641	Digital input 4	/	Event	
642	Digital input 5	/	Event	
643	Digital input 6	/	Event	
644	Digital input 7	/	Event	
645	Digital input 8	/	Event	
646	MBP Engaged	/	Major + R5	
647	Battery bad	/	Minor	Means that a test has failed
648	AC out 1 overload	/	Major	
649	AC out 1 redundancy lost	/	Event	
650	AC in freq out of limit	/	Minor	
651	Converter failure	/	Minor	
652	Temperature sensor 1 fail	/	Minor	Battery probe
653	Temperature sensor 2 fail	/	Minor	Battery probe
654	Not used	/	Event	
655	Module overtemperature	/	Minor	
656	Surge arrester	/	Minor	
657	AC out 1 redundancy +1 lost	/	Event	
658	AC out 1 saturated	/	Minor	System load is above the settable limit (normally 80%)
661	Battery 1 overvoltage	/	Event	
662	Battery 2 overvoltage	/	Event	
663	Battery 1 overtemperature	/	Event	
664	Battery 2 overtemperature	/	Event	
665	Battery 1 test active	/	Event	
666	Battery 2 test active	/	Event	
667	Battery 1 boost active	/	Event	
668	Battery 2 boost active	/	Event	
722	Battery test cancelled	/	Minor	Battery test has not started because of another event (See 530 -> 535)
723	SBP failure	/	Major	
724	SBP engaged	/	Major	
736	AC out 2 failure	/	Major	
737	AC out 2 overload	/	Major	
738	AC out 2 redundancy lost	/	Event	
739	AC out 2 redundancy +1 lost	/	Event	
740	AC out 2 saturated	/	Minor	

Mappable Events (Not alarms !!)				
Text ID	Name	Level	Def. Map	Description
745	AC out 1 manual off	/	Event	
746	AC out 2 manual off	/	Event	
747	Log full	/	Minor	
758	MBP procedure	/	Major + R5	
759	Battery safe charging control	/	Major	

4.1.1 Module alarms (T4S)

Module alarms				
Text ID	Name	Level	Def. Map	Description
96	Start	Minor		System is starting
97	Boost not available	Minor		ACin and ACout not synchronized (boost cannot be used)
98	Boost recovery	Minor		Boost (triac) cooling down from previous activation
99	Boost failure	Minor		Boost (triac) fault short-circuit
100	Fan to be replaced	Minor		The timeout indicating FAN operates for 7 years
101	Fan failure	Minor		Fans are not functioning properly
102	Power disturbed	Minor		Transient power alarm with output stopped (module KO)
103	Param phase query	Minor		No assigned AC group or DC group yet (in progress)
104	Param mismatch	Minor		Param not compatible with the rest of the system
105	No source	Minor		No AC/DC input
106	Vcap too high	Minor		Internal voltage too high
107	Vcap too low	Minor		Internal voltage too low
108	Vref error	Minor		Reference voltage from auxiliary supply out of acceptable range
109	Memory eeprom error	Minor		Not implemented
110	Memory flash error	Minor		Flash continuous verification failed
111	OFF remote	Minor		Module remote OFF
112	OFF manual	Minor		Module OFF manually (ON / OFF switch)
113	BUS com fail	Minor		Too many missing bus frames
114	Bus A fail	Minor		Sync tops reception issue on bus A (com lost)
115	Bus B fail	Minor		Sync tops reception issue on bus B (com lost)
116	Bus sync filter error	Minor		Sync top filtering circuit fault (detected because sync tops are received at different times)

T4S Alarms

Module alarms				
Text ID	Name	Level	Def. Map	Description
117				
118				
119	Bus A not present	Minor		bus A present signal of backplane not seen by the module
120	Bus B not present	Minor		bus B present signal of backplane not seen by the module
121	Bus frame collision	Minor		Bus A and bus B are not identical in content
122	Bus fail	Minor		Module can't see what it writes on both bus
123	Warm up too high	Minor		One of the measured temperature is above a threshold
124	Power noise	Minor		Transient power alarm (some trips happening)
125	Not defined 30			
126	Not defined 31			
127	Not defined 32			

Module DC input alarms				
Text ID	Name	Level	Def. Map	Description
128	Start up	Minor		
129	Temperature derating	Minor		Power is decreased due to high temperature
130	Temperature too high	Minor		DC converter stopped because of too high temperature
131	Temperature sensor fail	Minor		Communication with temperature probe was lost
132	Auto-calib error	Minor		Error during auto calibration of current offsets
133	Pdc too low	Minor		$P_{dc} = f(V_{dc})$. Alarm if $P_{dc} < P_{out}$
134	Impedance too high	Minor		DC input too high impedance detected
135	No AC voltage	Minor		For PV (photo-voltaïque) mode
136	Current trip	Minor		Too many consecutive DC-/+ over-current trips
137	Driver error	Minor		Too many "not ready"/"fault" from DC-/+ drivers over some time
138	Not defined 43			
139	Not defined 44			
140	Not defined 45			
141	Not defined 46			

Module DC input alarms				
Text ID	Name	Level	Def. Map	Description
142	Not defined 47			
143	Not defined 48			
144	Source+ too low - transferred	Minor		DC+ V is under input transfer to AC threshold
145	Source- too low - transferred	Minor		DC- V is under input transfer to AC threshold
146	Source+ too high - transferred	Minor		DC+ V is over input transfer to AC threshold
147	Source- too high - transferred	Minor		DC- V is over input stop threshold
148	Source+ too low - stop	Minor		DC+ V is under input stop threshold
149	Source- too low - stop	Minor		DC- V is under input stop threshold
150	Source+ too high - stop	Minor		DC+ V is over input stop threshold
151	Source- too high - stop	Minor		DC- V is over input stop threshold
152	Source+ no voltage	Minor		DC+ V is under input not present threshold
153	Source- no voltage	Minor		DC- V is under input not present threshold
154	Source+ brownout (<150V)	Minor		DC+ V is under extended lower limit for too much time
155	Source- brownout (<150V)	Minor		DC- V is under extended lower limit for too much time
156	Not defined 61			
157	Not defined 62			
158	Not defined 63			
159	Not defined 64			

Module AC input alarms				
Text ID	Name	Level	Def. Map	Description
160	Start	Minor		
161	Temperature derating	Minor		Power is decreased due to high temperature

Module AC input alarms				
Text ID	Name	Level	Def. Map	Description
162	Temperature too high	Minor		ACin converter stopped because of too high temperature
163	Temperature sensor fail	Minor		Communication with temperature probe was lost
164	Auto-calib error	Minor		Error during auto-calibration of current offsets
165	Impedance Too High	Minor		AC input too high impedance detected
166	Backfeed error	Minor		Input stopped because of backfeed on it
167	Not defined 72			
168	Overcurrent	Minor		Too many consecutive ACin over-current trips
169	Driver not ready	Minor		Hardware driver not ready signal received
170	Driver fault	Minor		Hardware driver fault signal received
171	Driver perturbed	Minor		Too many consecutive "not ready"/"fault" from ACin driver or more than a threshold over some hours
172	Not defined 77			
173	Not defined 78			
174	Not defined 79			
175	Vres Absent	Minor		Fast alarm when source V is no longer present
176	Source V too low transferred	Minor		Source V is under input transfer to DC threshold
177	Source V too high transferred	Minor		Source V is over input transfer to DC threshold
178	Vres out of range	Minor		Source V is out of expected envelope
179	Source V too low stop	Minor		Source V is under input stop threshold
180	Source V too high stop	Minor		Source V is over input stop threshold
181	Source frequ too low	Minor		Source freq is under input stop threshold
182	Source frequ too high	Minor		Source freq is over input stop threshold
183	Source no voltage	Minor		Source V RMS is below 60V (SELV threshold) - no sync possible
184	SBP Vres absent	Minor		SBP Fast alarm when SBP source V is no longer present
185	SBP Source V too low stop	Minor		SBP source V is under output stop threshold
186	SBP Source V too high stop	Minor		SBP source V is over output stop threshold
187	SBP Source frequ too low	Minor		SBP source freq is under output stop threshold

Module AC input alarms				
Text ID	Name	Level	Def. Map	Description
188	SBP Source frequ too high	Minor		SBP source freq is over output stop threshold
189	SBP Res not sync	Minor		SBP source is not in sync (freq + phase shift) with system
190	Not defined 95			
191	Not defined 96			

Module AC output alarms				
Text ID	Name	Level	Def. Map	Description
192	Start	Minor		
193	Temperature derating	Minor		Power is decreased due to high temperature
194	Temperature too high	Minor		ACout converter stopped because of too high temperature
195	Temperature sensor fail	Minor		Communication with temperature probe was lost
196	Auto-calib error	Minor		Error during auto calibration of current offsets
197	Overload not ready	Minor		Overload capability is in cool-down
198	Overload	Minor		Output power is higher than a threshold above nominal power
199	Power derating	Minor		Derate output power because it cannot be supplied
200	Vout too Low	Minor		Output V is under a threshold (due to an overload)
201	Overload too long	Minor		Output V is under a threshold (due to an overload) for too much time
202	Vout modify	Minor		Output V setpoint was modified and is being converged on
203	Load-sharing low	Minor		AGIL module is supplying too much power to the load compared to the other modules
204	Load-sharing high	Minor		AGIL module is not supplying enough power to the load compared to the other modules
205	Mode support	Minor		AGIL is supporting either the SBP or MBP output, i.e. it does not supply any current, but in case of a voltage drop will try to keep the voltage at an acceptable level
206	Igbt driver alarm	Minor		An individual driver is sending an alarm but global drivers monitoring signals are OK
207	Not defined 112			
208	Driver not ready	Minor		Hardware driver not ready signal received
209	Driver fault	Minor		Hardware driver fault signal received

Module AC output alarms				
Text ID	Name	Level	Def. Map	Description
210	Over-current	Minor		Too many consecutive ACout over-current trips
211	Igbt error	Minor		Software detected IGBT fault
212	Vout pi2 error	Minor		Output V at Pi/2 (sine max) is out of expected range with open relay
213	Vout mpi2 error	Minor		Output V at -Pi/2 (sine min) is out of expected range with open relay
214	Off (bus)	Minor		Output Off from bus request
215	Backfeed error	Minor		Output stopped because of backfeed from this module or another one
216	Too many start	Minor		Too many attempts to start output over some time
217	AC out fuse open	Minor		Output fuse open or eventually output connector not connected
218	SBP AC out open	Minor		SBP could not close when needed
219	SBP AC out short circuit	Minor		SBP could not open when needed
220	SBP temperature too high	Minor		SBP stopped because of too high temperature
221	SBP temperature sensor fail	Minor		Communication with temperature probe was lost
222	SBP overload	Minor		SBP Output power is higher than a threshold above nominal power (105%) (not KO)
223	SBP overload too long	Minor		SBP Output power is higher than a threshold (200%) above nominal power for too much time (KO)

ANNEXE 5. FAQ

How can I reset my admin password if I have unfortunately forgotten it?

Before version 3.1, there is a generic password that always works: 123TEC. You can use it to connect and change your expert password. As this has been identified as a potential risk for system integrity, we strongly recommend to update to a newer version where security has been improved.

From version 3.1, in case of password loss, a new temporary password (valid 24 hrs after creation) can be issued by CE+T Power. To receive a temporary password, send an email with your T4S serial Number and the date at which you expect to go back on site to change the password to customer.support@cet-power.com specifically requesting a new temporary password. The serial number can be found on the sticker on the T4S, or on screen in 'Parameters' then 'Info'.

